

Rosemount™ Oxymitter 4000

Hazardous Area In-Situ Oxygen Transmitter

- **Outstanding accuracy**
- **Electronics mounted to probe or separate**
 - $\pm 0.75\%$ of reading or $\pm 0.05\% \text{ O}_2$
- **Optional Xi advanced electronics**
 - Large backlit LCD display
 - Advanced software features
 - Wireless - via THUM™ Adaptor
- **Adaptable** to any existing O_2 probe installation
- **Advanced sensor diagnostics**
 - Alarm indicates when calibration is recommended.
- **Optional explosion-proof rating**
 - ATEX II 2G Exd IIB +H2 T4 Gb
 - Class I, Div. I, Groups B, C and D
- **Digital HART® communication**
 - AMS/PlantWeb® compatible
- **Fully field-repairable**
- **HART® wireless** communication from probe or Xi



Integral or Remote electronics



Wireless THUM™ Adaptor mounts to either electronics (Div. II/Zone II or GP only)



Optional Xi enhanced interface (Safe area only)

ROSEMOUNT™

EMERSON™

The Latest Breakthrough For Combustion Flue Gas Analysis

The Oxymitter In-Situ Oxygen Transmitter was the world's first in-situ, zirconium oxide-based oxygen transmitter for flue gas measurement. These oxygen measurements can be used in a control system or by a boiler operator to fine tune burner fuel/air ratios for maximum efficiency. Ideal for:

- Boilers
- Process Heaters
- Kilns
- Reheat furnaces

Emerson is the leader in oxygen flue gas analyzer technology. Our in-situ, zirconium oxide oxygen analyzers have long been established as industry standards. We've combined our expertise with the latest Rosemount transmitter technology to create a truly revolutionary package – the Oxymitter.

The Oxymitter integrates an oxygen probe and field electronics into a single, compact package. The probe inserts directly into a flue gas duct to measure oxygen in combustion processes. No sampling system is required.

A NEMA 4X, IP 66 Rosemount transmitter housing mounts directly to the probe and contains the transmitter's electronics, replacing common stand-alone field electronics. This integrated design minimizes the costs of installing separate probe cable, conduit and electronics. The Oxymitter electronics also require 95% less power to operate. So its components last longer. We also offer traditional architecture with remote-mounted electronics.

The HART® protocol provides a link into Emerson's PlantWeb® field-based architecture. Instrument technicians can interface with the Oxymitter from the control room or any location where the transmitter's signal wires terminate. Service diagnostics and calibrations can be performed remotely with a HART hand-held communicator or a personal computer equipped with AMS.

The Oxymitter is fully field-repairable. The probe's design provides convenient access to internal probe components so technicians can service the unit in house. The cell and heater/thermocouple are fully field-replaceable. The Oxymitter contains no potentiometer adjustments or jumpers.

The Oxymitter In-Situ Oxygen Transmitter operates at process temperatures up to 700 °C (1300 °F), providing a fast response with high accuracy and reliability. Available lengths from 18 inches to 18 feet.

Optional accessories for the Oxymitter include:

- Auto calibration gas sequencer
- Remote, loop-powered Vacuum Fluorescent display of oxygen reading
- High temperature accessories for temperatures up to 100 °C (1832 °F)
- Flame arrestor
- Abrasive shield

The Oxymitter Oxygen Transmitter is Completely Field-Repairable

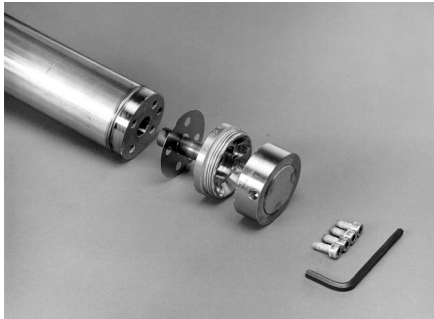

Diffusion filter and sensor cell assembly

- Outstanding accuracy— $\pm 75\%$ of reading or $.05\% O_2$
- Special cells for tough service in SO_2 and HCL
- Rugged steel cell holder – cells will not crack

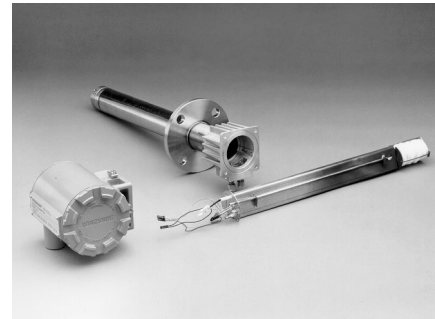

Heater/thermocouple assembly

Hazardous area – OXT4C



- ATEX II 2G Exd IIB +H2 T4 Gb
- CSA Class I, Div. I, Groups B, C and D
- Lengths from .9 m (18 in.) to 1.8 m (6 ft)

Electronics

- $-40\text{ }^\circ\text{C}$ to $70\text{ }^\circ\text{C}$ ($-40\text{ }^\circ\text{F}$ to $185\text{ }^\circ\text{F}$) ambient temperature limit
- HART communications
- “Calibration Recommended” diagnostic

Hazardous area electronics integral to probe, or remote mounted



- Lowest cost of installation
- Bright gas fluorescent local operator interface (LOI)
- Thru-glass infrared pushbuttons are suitable for hazardous areas

General purpose Xi Electronics



- Easy-to-read backlit display
- Easy-to-use keypad
- IP66 (NEMA 4X) enclosure (general purpose only)
- Advanced software features
- Loss of flame relay option turns heater off upon flame loss

Advanced Software Features (available only with the Xi electronics)

Extended Process Temperature Range to 800 °C (1562 °F)

The oxygen analyzer employs a heater and thermocouple to maintain a temperature setpoint at 736 °C (1357 °F). Temperature control is maintained within ±1 °C to process temperatures of about 705 °C (1300 °F). This is satisfactory for most applications, but excursions to higher temperatures can occur in many processes. In these instances, the heater is turned off and the process temperature is utilized to heat the sensing cell.

The oxygen reading is adjusted immediately to compensate for the varying process temperatures. It should be noted that cell life will be reduced by continuous operation at temperatures above 705 °C (1300 °F). If process temperatures are expected to continuously be above 705 °C, we recommend the use of a bypass or probe mounting jacket accessory (see page 10).



Acid-resistant stoichiometer cell

Stoichiometer

Process upsets can sometimes cause a combustion process to go into substoichiometric or reducing conditions. The oxygen readings from one or more probes may decline all the way to zero. The stoichiometer cell will measure the amount of oxygen deficiency during these reducing conditions. The trends in your DCS can be set up for a lower range limit of -1 or -2% oxygen to depict the level of oxygen deficiency.

The operator can see if his control actions to recover are having the desired effect. These types of events do not occur frequently, but knowing the parameters of the situation prevents overcorrecting while coming out of the reducing condition.

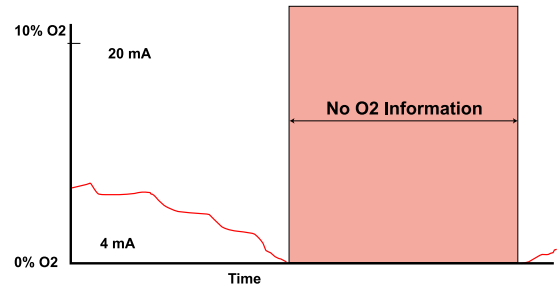

Typical DCS trend during a reducing process event

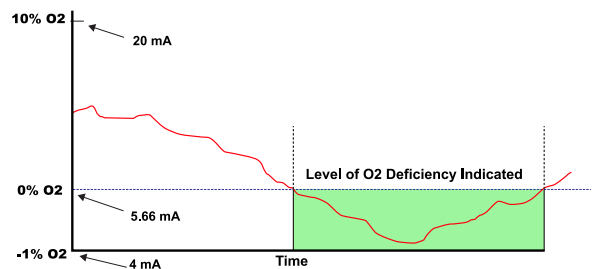

DCS trend with stoichiometer feature

Programmable Reference

The zirconium oxide sensing technology has historically measured process oxygen by using ambient or instrument air as a reference (20.95% oxygen). The sensor develops most of its signal at the low oxygen levels typically found in combustion flue gases (2-4% oxygen) and is most accurate at these levels. When measuring at levels near ambient, however, the sensor develops only a few millivolts of signal and accuracy degrades.

Typical applications include:

Flue gas recirculation – controlling the mixing of flue gases into the burner windbox prior to the burner to reduce

Moisture monitoring – measuring the amount of moisture coming off of industrial dryers by noting the dilution effect

Enriched oxygen combustion – Pure oxygen is sometimes mixed in with the combustion air to increase heat at the flame. This is used in steel and other metals reduction processes and also in some catalyst regenerators.

Specifications¹

Measurement Specifications

Net O₂ range

variable 0-10% to 0-40%

(Xi electronics offer 0-50% O₂ range)

Accuracy in oxidizing conditions

±0.75% of reading or 0.05% O₂, whichever is greater

Lowest detectable limit

0.02% O₂

Process temperature effect

less than 0.05% O₂ from 100 to 700 °C (212 to 1292 °F)

System speed of response to calibration gas

Initial response in less than 3 seconds, T90 in less than 8 seconds. Response to process gas changes will vary, depending on process gas velocity and particulate loading of the diffuser.

Calibration validity

Presentation of calibration gases matches the normal process to within ±0.02% O₂.

Accuracy in reducing conditions

±0.10% of reading, or 0.1% O₂, whichever is greater

System response in reducing conditions

Going from oxidizing to reducing -T90 in 120 sec.

Going from reducing to oxidizing -T90 in 30 sec.

Environmental Specifications

Transmitter probe

Transmitter probe

Process-wetted materials are 316L or 304 stainless steel

Process temperature limits

0 to 705 °C (32-1300 °F) with Oxymitter electronics

0 to 800 °C (32-1472 °F) with Xi electronics *reduced cell life can be expected if operated continuously at temperatures above 705 °C (1300 °F) optional bypass and jacket accessories permit operation to 1050 °C (1922 °F)

Oxymitter Transmitter electronics housing (integral to probe or remote mounted)

Low copper aluminum IP 66 (NEMA 4X), with reference air exhaust port piped to clean area

Oxymitter electronics ambient temp. limits

-40 to 80 °C (-40 to 176 °F)

Temperature limit as measured inside Oxymitter electronics

-40 to 85 °C (-40 to 185 °F)

Optional Xi Electronics

Optional Xi Electronics

NEMA 4X, polycarbonate material

General purpose certifications



Xi ambient temperature limits

-20 to 55 °C (-4 to 131 °F)

Xi temperature limits as measured inside the electronics housing

-20 to 55 °C (-4 to 131 °F)

Xi LCD display temperature limits

-20 to 55 °C (-4 to 131 °F)

Installation Specifications

Probe mounting flange

Vertical or horizontal — 2 in. 150# (121 mm (4.75 in.) bolt circle)

DIN (145mm (5.71 in.) bolt circle)

Note: Flanges are flat-faced and for mounting only. Flanges are not pressure-rated.

Spool piece P/N 3D39761G02 is available to offset probe electronics housing from hot ductwork.

Many adapter flanges are available to mate to existing flanges.

Probe lengths and approximate shipping weights

457 mm (18 in.) package:	7.3 kg (16 lb)
.91 m (3 ft) package:	9.5 kg (21 lb)
1.83 m (6 ft) package:	12.2 kg (27 lb)

Reference air (optional)

.5 scfh (.24 L/m), clean, dry, instrument quality air (20.95% O₂), regulated to 2.5 psi (34 kPa)

Specifications (cont.)

Calibration

Semi-automatic or automatic

Cal gases

.4% O₂ and 8%, balance N₂ recommended

Cal gas flow

5 scfh (2.5 L/m)

Heater electrical power

100 - 240 V, ±10% 50/60 Hz 1/2 in. — 14 in. NPT conduit ports

Traditional architecture cable

61 m (200 ft) maximum length

Power consumption of probe heater

776 VA maximum during warm-up

Electrical power of Oxymitter or optional Xi Electronics

120 to 240 V, ±10% 50/60 Hz

Power consumption of Xi

10 watts maximum

Xi alarms relays

2 provided - 2 amps, 30 Vdc

Xi optional loss of flame contact

Removes heater power

Electrical Noise

Meets EN 61326, Class A

Optional hazardous area certifications

Hazardous area Oxymitter with integral electronics

With cell-end flame arrestor

- ATEX II 2G Exd IIB +H2 T4 Gb

Without cell-end flame arrestor

- ATEX II 2/-G Exd IIB +H2 T4 Gb/-

CSA Class I, Division 1, Groups B, C, D, and T2

Class I, Zone 1, Ex d IIB+H2 T2

Class I, Zone 1, AEx d IIB+H2 T2

Hazardous area Oxymitter with remote electronics

With cell-end flame arrestor

- ATEX II 2G Exd IIB +H2 T4 Gb

Without cell-end flame arrestor

- ATEX II 2/-G Exd IIB +H2 T4 Gb/-

(remote electronics) ATEX II 2G Exd IIB +H2 T5 Gb

CSA Class I, Zone 1, Ex d IIB+H2 T2 (Remote Probe)

Class I, Zone 1, Ex de IIB+H2 T6 (Remote Electronics)

Class I, Zone 1, AEx d IIB+H2 T2 (Remote Probe)

Class I, Zone 1, AEx de IIB+H2 T6 (remote electronics)

* **Note that optional Xi electronics are designed for general purpose use only.**

Traditional architecture cable

61 m (200 ft) maximum length

Power consumption of probe heater

776 VA maximum during warm-up

Transmitter Electrical Power

12 – 42 Vdc, (loop-powered from the control room or from the Xi box)

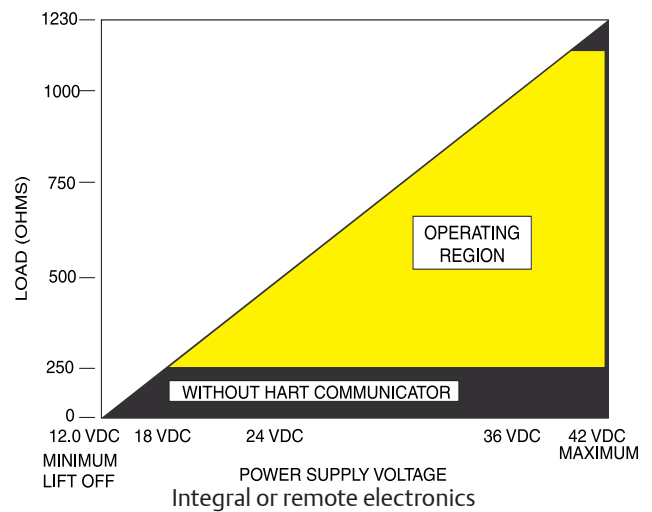

Electrical power for Xi

100-240V ±10%, 50-60 Hz

Power consumption of Xi

12 VA maximum or 776 VA maximum with traditional architecture, 120 V, probes. 450 VA maximum with traditional architecture, 44 V probes

Alarm relay outputs

Two provided - 2 Amperes, 30 Vdc, Form-C

Optional loss of flame input:

Internally power input to remove heater power, actuated via dry contact output from prove of flame device.

CE Emerson has satisfied all obligations coming from the European legislation to harmonize the product requirements in Europe.
 † All static performance characteristics are with operating variables constant. Specifications subject to change without notice.

Outline Dimensions for Oxymitter Hazardous Area Oxygen Transmitter

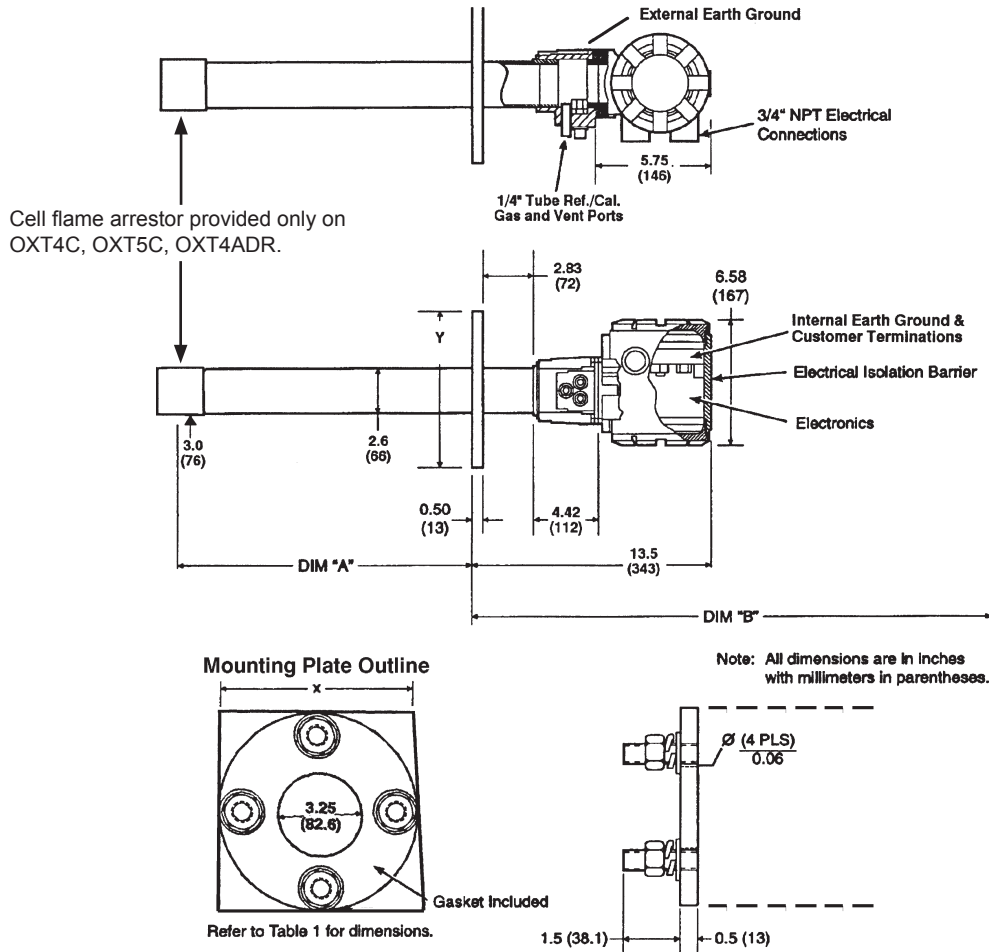

Table I. Mounting plate		
	Dimensions dia. in. (mm)	
	ANSI	DIN
Mtg. plate (x)	7.75 (197)	8.5 (215)
Stud size	5/8 in. - 11	M16 X 2
4 studs eq.	6.00 BC	6.70 BC
Sp. on BC	(152.4) BC	(170) BC
Flange (Y)	7.5 (190)	8.27 (210)

Table II. Removal/Installation		
Probe length	Dim "A" insertion depth	Dim "B" removal envelope
18 in. (457 mm) probes	18.1 (460)	31.6 (803)
3 ft (0.91 m) probes	36.1 (917)	57.0 (1448)
6 ft (1.83 m) probes	72.1 (1831)	85.6 (2174)

Ordering Information

Hazardous Area Oxymitter with HART Communications. Cell flame arrestor included (process gases are considered to be within hazardous area). Optional Xi electronics not applicable.

Model	Product description
OXT4C	In-Situ Oxygen Transmitter – explo-proof – HART® Smart (Oxymitter 4000)
Sensing probe type with flame arrestor	
1	Ceramic diffusion element probe (ANSI) 3 in. 150 lb bolt circle
2	Snubber diffusion element (ANSI) 3 in. 150 lb bolt circle
3	Ceramic diffusion element probe (DIN 2527) 1/4 in. tube fittings
4	Snubber diffusion element (DIN 2527) 1/4 in. tube fittings
7	Ceramic diffusion element probe (ANSI) 3 in. 300 lb bolt circle
8	Ceramic diffusion element probe (ANSI) 4 in. 300 lb bolt circle
Probe assembly	
0	457 mm (18 in.) probe
3	0.91 m (3 ft) probe
5	1.83 m (6 ft) probe
Mounting adapter (stack side)	
0	No adapter plate (0 must also be chosen under Mounting adapter – probe side)
1	New installation – square weld plate with studs
2	Model 218 mounting plate (with Model 218 shield removed)
3	Competitor's mount
Mounting adapter (probe side)	
0	No adapter plate
1	Probe only (ANSI)
4	Probe only (DIN)
Electronic housing and filtered customer termination – NEMA 4X, IP 66	
12	HART electronics, mounted integral to probe, transient protected termination, ATEX II 2G Exd IIB +H2 T4 Gb
14	HART electronics, mounted remotely, transient protected termination, requires cable ATEX II 2G Exd IIB +H2 T4 Gb
22	HART electronics, mounted integral to probe, transient protected termination, Class I, Div I, Group B, C, and D
24	HART electronics, mounted remotely, transient protected termination; requires cable CSA Class I, Div. I, Group B, C, and D
Communications	
1	Membrane keypad – HART capable
2	Membrane keypad – HART capable, glass window
3	Gas fluorescent LOI HART capable, glass window, English only
Language	
1	English
2	German
3	French
4	Spanish
5	Italian

Ordering information (Cont.)

Termination filtering	
00	Specified as part of electronic housing
Calibration accessories	
00	No hardware
01	Cal./ref. flowmeter and reference pressure regulator
02	Autocalibration Systems – order by separate part number (for safe areas only)
Hazardous area approval	
00	Specified as part of electronic housing
Electronics to probe cable	
00	No cable – integral electronics
10	6 m (20 ft) cable – remote electronics
11	12 m (40 ft) cable – remote electronics
12	18 m (60 ft) cable – remote electronics
13	24 m (80 ft) cable – remote electronics
14	30 m (100 ft) cable – remote electronics
15	45 m (150 ft) cable – remote electronics
16	61 m (200 ft) cable – remote electronics

Ordering Information

Hazardous Area direct replacement Oxymitter probe replaces older Westinghouse and Rosemount probes as well as most competitive probes. Cell flame arrestor included (process gases are considered to be within hazardous area). Optional Xi Electronics may be used, but in a general purpose area only.

Model	Product description
OXT4CDR	Direct replacement probe
Sensing probe type with flame arrestor	
1	Ceramic diffusion element probe (ANSI) 115 V heater
2	Snubber diffusion element (ANSI) 115 V heater
3	Ceramic diffusion element probe (DIN) 115 V heater
4	Snubber diffusion element (DIN) 115 V heater
7	Ceramic diffusion element probe (ANSI) 3 in. 300 lb ¹
8	Ceramic diffusion element probe (ANSI) 4 in. 300 lb ¹
A	Ceramic diffusion element probe (ANSI), with flame arrestor, 44 V heater
B	Snubber diffusion element (ANSI), with flame arrestor , 44 V heater
C	Ceramic diffusion element probe (DIN), with flame arrestor , 44 V heater
D	Snubber diffusion element (DIN), with flame arrestor , 44 V heater
Probe assembly	
0	457 mm (18 in.) probe
3	0.91 m (3 ft) probe
5	1.83 m (6 ft) probe
Mounting adapter (stack side)	
0	No adapter plate
1	Mounting to stack (new installation)
2	Model 218 mounting plate (with Model 218 shield removed)
3	Competitor's mount-supply existing flange dimensions
Mounting adapter (probe side)	
0	No mounting hardware
1	Mounting probe only (ANSI)
4	Mounting probe only (DIN)
Termination unit	
11	Standard filtered termination
12	Transient protected filtered termination
Arrangement-existing electronics	
03	No hardware. For use with 218 analog electronics, world-class IFT electronics or Oxymitter electronics, Xi Electronics
04	Westinghouse 218A digital electronics
05	Westinghouse/Rosemount digital electronics
07	Yokogawa series electronics – maximum operating temperature of junction box is 65 °C (149 °F)
08	Other competitive electronics – specify brand and model
09	For use with other competitive oxygen analyzer systems
Hazardous area approval	
10	ATEX II 2G Exd IIB +H2 T4 Gb
20	CSA – Class I, Div. I, Groups B, C, D, and T2

Note: Order manual calibration accessories separately
 263C152G01 Reference gas regulator/filter
 771B635H01 (2 required) Calibration and reference air flowmeters

Ordering Information

Hazardous area Oxymitter 4000 - In-Situ Oxygen Transmitter without process end flame arrestor (process gases are not to be considered in hazardous area).

Model	Product description
OXT4CNF	Oxymitter 4000 In-Situ Oxygen Transmitter
Sensing probe type	
1	Ceramic diffusion element probe (ANSI) 76.2 mm (3 in.) 150 lb flange
2	Snubber diffusion element (ANSI) 76.2 mm (3 in.) 150 lb flange
3	Ceramic diffusion element probe (DIN) 210 mm (8.27 in.) dia. flange
4	Snubber diffusion element (DIN) 210 mm (8.27 in.) dia. flange
7	Ceramic diffusion element probe (ANSI) 76.2 mm (3 in.) 300 lb flange for acidic service
8	Ceramic diffusion element probe (ANSI) 101.6 mm (4 in.) 300 lb flange for acidic service
Probe assembly	
0	457 mm (18 in.) probe
3	0.91 m (3 ft) probe
5	1.83 m (6 ft) probe
Mounting adapter (stack side)	
0	No adapter plate (0 must also be chosen under Mounting adaptor- probe side below)
1	New Installation – square weld plate with studs
2	Model 218 mounting plate (with Model 218 shield removed)
3	Competitor's mount
Mounting adapter (probe side)	
0	No adapter plate
1	Probe only (ANSI)
4	Probe only (DIN)
Electronic housing and filtered customer termination – NEMA 4X, IP 66	
12	Integral - transient protected filtered termination – ATEX II 2/-G Exd IIB +H2 T4 Gb/-
14	Split architecture - transient protected filtered termination – ATEX II 2/-G Exd IIB +H2 T4 Gb/-
22	Integral - transient protected filtered termination – CSA
24	Split architecture - transient protected filtered termination – CSA
Communications	
1	Electronics with membrane keypad w/blind cover
2	Electronics with membrane keypad w/window cover
3	Electronics with LOI display w/window cover (English only)
Language	
1	English
2	German
3	French
4	Spanish
5	Italian
Calibration accessories	
00	No hardware
01	Cal/ref flowmeters and ref pressure regulator

Ordering Information (Cont.)

Hazardous area Oxymitter 4000 - In-Situ Oxygen Transmitter without process end flame arrestor (process gases are not to be considered in hazardous area).

Electronics to probe cable	
00	No Cable - intergal electronics or reusing existing cable
10	6 m (20 ft) cable
11	12 m (40 ft) cable
12	18 m (60 ft) cable
13	24 m (80 ft) cable
14	30 m (100 ft) cable
15	45 m (150 ft) cable
16	60 m (200 ft) cable

Ordering Information

Hazardous area Oxymitter DR - In-Situ Oxygen Transmitter without process end flame arrestor. Optional Xi electronics may be used, but in a general purpose area only.

Model	Product description
OXT4CDRNF	Oxymitter DR In-Situ Oxygen Transmitter, optional Xi Advanced Electronics may be used safe area only.
Sensing probe type	
1	Ceramic diffusion element probe (ANSI) 76.2 mm (3 in.) 150 lb. flange
2	Snubber diffusion element (ANSI) 76.2 mm (3 in.) 150 lb. flange
3	Ceramic diffusion element probe (DIN) 210 mm (8.27 in.) dia. flange
4	Snubber diffusion element (DIN) 210 mm (8.27 in.) dia. flange
7	Ceramic diffusion element probe (ANSI) 76.2 mm (3 in.) 300 lb. flange for acidic service
8	Ceramic diffusion element probe (ANSI) 101.6 mm (4 in.) 300 lb. flange for acidic service
Probe assembly	
0	457 mm (18 in.) probe
3	0.91 m (3 ft) probe
5	1.83 m (6 ft) probe
Mounting adapter (stack side)	
0	No adapter plate (0 must also be chosen under Mounting Adaptor - Probe side below)
1	New installation – square weld plate with studs
2	Model 218 mounting plate (with Model 218 shield removed)
3	Competitor's mount
Mounting adapter (probe side)	
0	No adapter plate
1	Probe only (ANSI)
4	Probe only (DIN)
Electronic housing and filtered customer termination – NEMA 4X, IP 66	
12	Transient protected filtered termination
Arrangement	
03	No hardware. For use with 218 analog electronics, world-class IFT electronics or Oxymitter electronics, Xi electronics
04	(1A) digital
05	(1A) digital
07	(1A) Model 132 digital
08	Yokagawa electronics
09	Other competitive electronics
Hazardous area approval	
10	ATEX II 2/-G Exd IIB +H2 T4 Gb/-
20	CSA

Note: Order manual calibration accessories separately:
 263C152G01 Reference gas regulator/filter
 771B635H01 (2 required) Calibration and reference air flowmeters

Option Notes For All Preceding Matrices

Generalnotes
<p>In-Situ Oxygen Transmitter – explo-proof – HART Smart</p> <p>High sulfur service:</p> <p>High sulfur cell can be selected for any probe; add a line item note to your purchase order requesting the high sulfur</p> <p>ZrO₂ cell in place of the standard ZrO₂ cell. Add 4232 UOM to the system matrix UOM total.</p> <p>Example:</p> <p>Note: Delete – standard cell P/N 4847B63G01</p> <p>Add – high sulfur cell P/N 4847B63G02</p> <p>Cell replacement kits for high sulfur service are also available. Consult P/N 4849B94XX in the Combustion Solutions Center spare parts list.</p>
Level 1
<p>Option: 7, 8</p> <p>Probe is set up for high acid service in catalytic regenerators; includes: SO₂/HCL resistant cell, Hastelloy C and Viton materials for calibration gas line larger than standard flange.</p>
Level 3
<p>Option: 3</p> <p>Where possible, specify SPS number; otherwise provide details of the existing mounting plate as follows:</p> <p>Plate with studs: Bolt circle diameter, number and arrangement of studs, stud thread, stud height above mounting plate.</p> <p>Plate without studs: Bolt circle diameter, number and arrangement of holes, thread, depth of stud mounting plate with accessories.</p>
Level 6
<p>Option: 1</p> <p>Startup, calibration and operation can be implemented using the standard membrane keypad. Remote access and additional functionality available via HART Communications (Model 375 hand-held communicator or AMS) with Oxymitter device descriptor (DD) required.</p>

Xi Enhanced Interface Mounting Details

Panel mounting details

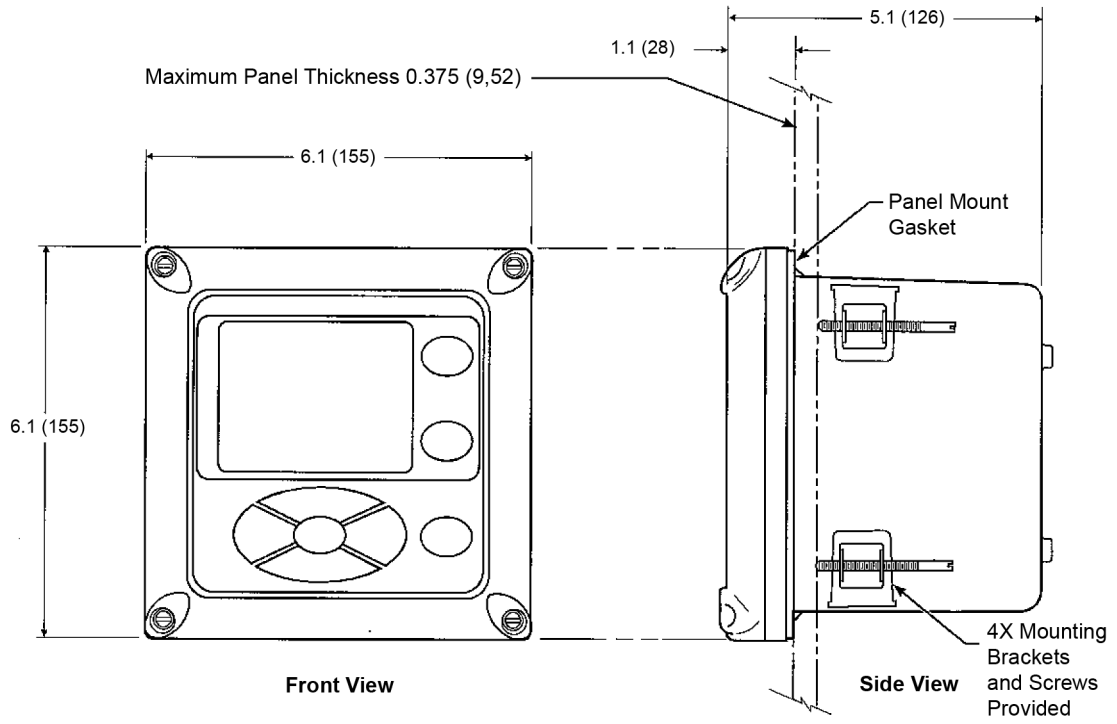

Xi Enhanced Interface Mounting Details

Wall/surface and pipe mounting details

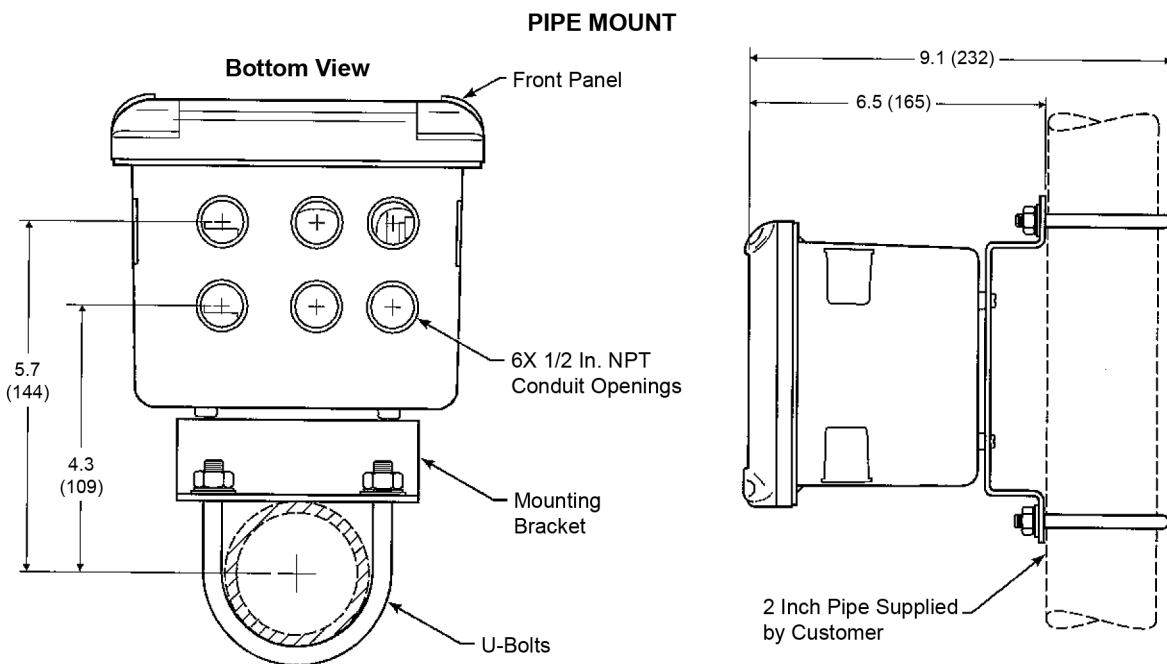
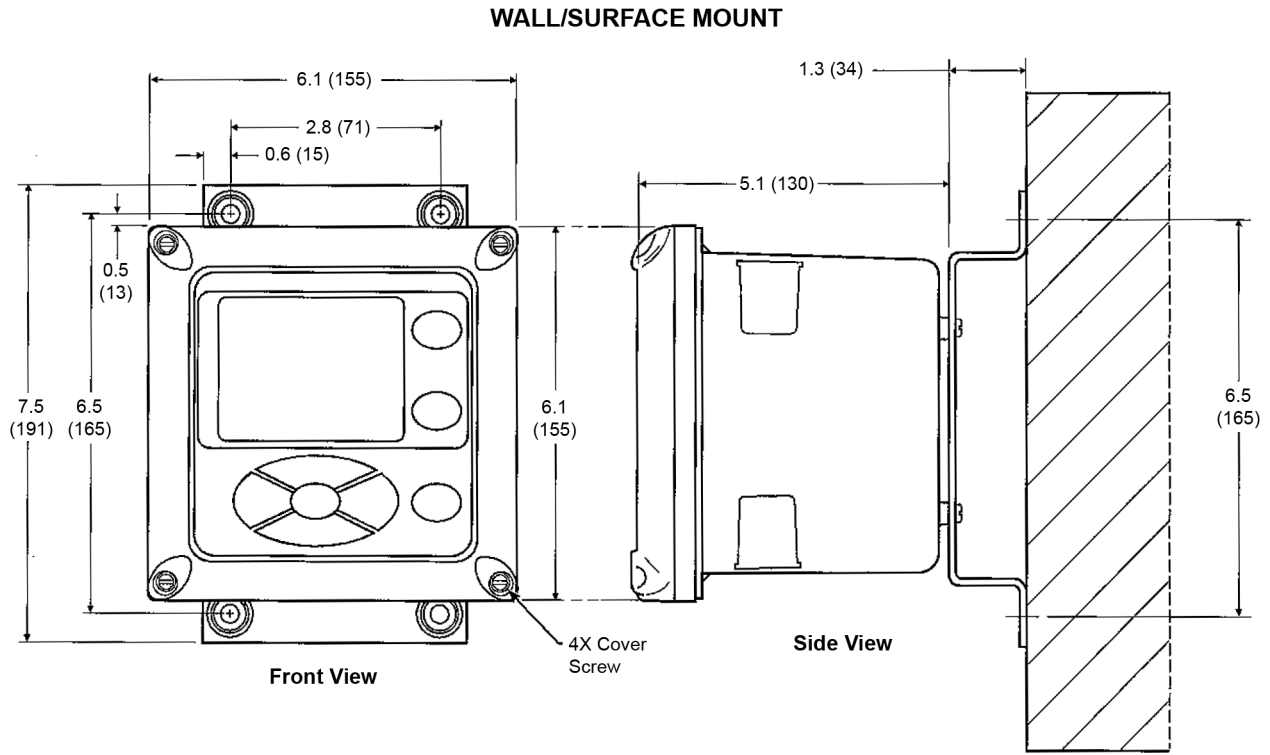

Ordering Information

Optional Xi Advanced Electronics safe area only.

Model	Product description
Xi	O ₂ Advanced Electronics
Xi type	
01	Future
02	Future
03	Future
04	Traditional architecture Xi - all signal conditioning and operator interface via the Xi. Cable required, single channel only.
05	Traditional architecture Xi - all signal conditioning and operator interface via the Xi. Cable required, single channel only, set up to run 44 V world class probe
Mounting	
00	None
01	Panel mount kit with gasket
02	2 in. pipe/wall mount kit
Cable (for traditional architecture Xi only)	
00	None
10	6 m (20 ft) cable
11	12 m (40 ft) cable
12	18 m (60 ft) cable
13	24 m (80 ft) cable
14	30 m (100 ft) cable
15	45 m (150 ft) Cable
16	60 m (200 ft) Cable
Stoichiometer function	
00	No
01	Single Channel
02	Dual Channel, (second channel not available for traditional architecture Xi)
Programmable reference function	
00	No
01	Single Channel
02	Dual Channel, (second channel not available for traditional architecture Xi)
825 °C process function	
00	No
01	Single Channel
02	Dual Channel, (second channel not available for traditional architecture Xi)

Note: Order Direct Replacement Oxymitter probe separately

Ordering Information

Autocalibration accessories - must be mounted in a safe area.

Model	Product description
XSO2CAL	O ₂ autocalibration accessories - apply to Oxymitter or Xi electronics. General purpose only.
Single probe sequencers autocalibration options	
00	None
01	SPS 4001 Single Probe Sequencer, general purpose NEMA 4X, includes check valve for probe
Intelligent Multiprobe Sequencers (IMPS)	
00	None
01	IMPS Intelligent Probe Sequencer, single-probe, general purpose NEMA 4X, includes valve for probe
02	IMPS Intelligent Probe Sequencer, two-probe, general purpose NEMA 4X, includes valve for probe
03	IMPS Intelligent Probe Sequencer, three-probe, general purpose NEMA 4X, includes valve for probe
04	IMPS Intelligent Probe Sequencer, four-probe, general purpose NEMA 4X, includes valve for probe
05	IMPS Intelligent Probe Sequencer, single-probe, 115 V heated general purpose NEMA 4X, includes valve for probe
06	IMPS Intelligent Probe Sequencer, two-probe, 115 V heated general purpose NEMA 4X, includes valve for probe
07	IMPS Intelligent Probe Sequencer, three-probe, 115 V heated general purpose NEMA 4X, includes valve for probe
08	IMPS Intelligent Probe Sequencer, four-probe, 115 V heated general purpose NEMA 4X, includes valve for probe
09	IMPS Intelligent Probe Sequencer, single-probe, 220 V heated general purpose NEMA 4X, includes valve for probe
010	IMPS Intelligent Probe Sequencer, two-probe, 220 V heated general purpose NEMA 4X, includes valve for probe
011	IMPS Intelligent Probe Sequencer, three-probe, 220 V heated general purpose NEMA 4X, includes valve for probe
012	IMPS Intelligent Probe Sequencer, four-probe, 220 V heated general purpose NEMA 4X, includes valve for probe

Oxymitter Accessories

HART Hand-held 475 Communicator

The 475 Communicator is an interface device that provides a common communication link to HART compatible instruments. HART communications protocol permits all the information available from the electronics to be transmitted over standard 4-20 mA signal wires. By attaching the hand-held communicator at a termination point along the signal line, a technician can diagnose problems and configure and calibrate as if he or she were standing in front of the instrument.

For more information, call Rosemount at 1-855-724-2638.

Bypass Packages

The specially designed Rosemount Bypass Package for oxygen analyzers has proven to withstand the high temperatures in process heaters while providing the same advantages offered by the in-situ sensor. Inconel tubes provide effective resistance to corrosion, and the other components common to other sampling systems.

For more information, call Rosemount at 1-855-724-2638.

O₂ Calibration Gas Kits PN 6296A27G01

Rosemount's O₂ Calibration Gas and Service Kits have been carefully designed to provide a more convenient and fully portable means of testing, calibrating, and servicing Rosemount's oxygen analyzers. These lightweight, disposable gas cylinders eliminate the need to rent gas bottles.

For more information, call Rosemount at 1-855-724-2638.

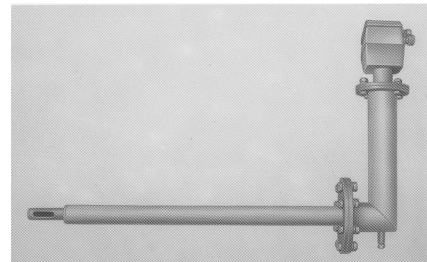

Oxymitter Accessories (Cont.)

Wireless THUM™ Adaptor

The Smart Wireless THUM Adaptor converts the standard 4-20mA signal from the Oxymitter or Xi Electronics to a wireless signal. All HART information is transmitted in addition to the process O₂ value. Safe area only.

For more information, call Rosemount at 1-855-724-2638.



Special Arrangements

Special cells for high acid service

Many combustion processes use fuels that contain sulfur or HCl. Special cells provide extended life in these difficult applications.

Catalyst regeneration

Measure O₂ in regenerators at pressures up to 50 psi. In-situ design resists plugging due to catalyst fines Class I, Div. I, Group B, C, and D. Optional pressure balancing arrangement. Optional isolation valving system permits installation and withdrawal while the process is running. Specified by UOP. See Application Data Sheet ADS 106-300F.A01.

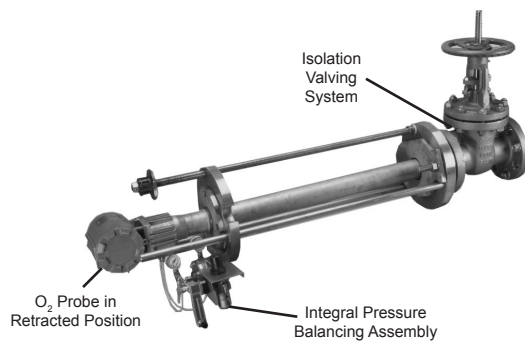
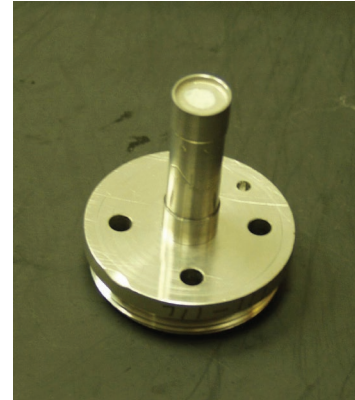

Pressure balanced in-situ O₂ probe with optional isolation valving system (probe withdrawn)