

Rosemount™ 2140 and 2140:SIS Level Detectors

Vibrating Fork



- Integrates into existing wired HART® loops of automated systems without extra wiring costs
- Switch between HART 5 and HART 7
- Industry first “Media Learn” functionality
- Exclusive liquid-to-sediment detection capability
- Increased safety, IEC 61508 certified (SIL 2) as required by IEC 61511
- Unique remote proof testing
- Smart Diagnostics Suite



Introduction

Emerson's™ Rosemount 2140 and 2140:SIS Level Detectors are the newest additions to the expanding range of vibrating forks. Utilizing the wired HART® protocol, they can be easily integrated into automated systems without the need for additional wiring. Switch easily between HART 5 and HART 7 to further meet requirements.



'Fast drip' forks

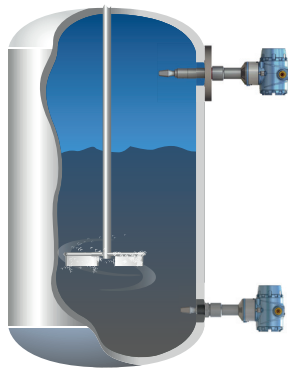

High and low level alarm applications

Measurement principle

The Rosemount 2140 and 2140:SIS are liquid point level devices, and are designed to use the principle of a tuning fork. A piezo-electric crystal oscillates the forks at their natural frequency, and changes to this frequency are continuously monitored. The frequency of the vibrating fork sensor changes depending on the medium in which it is immersed.

When used as a **low level alarm**, the liquid in the tank or pipe drains down past the fork, causing a change of frequency that is detected by the electronics and switches the output state.

When used as a **high level alarm**, the liquid rises in the tank or pipe and makes contact with the fork. The resulting change of frequency is detected and switches the output state.

Key features and benefits

- Virtually unaffected by turbulence, foam, vibration, solids content, coating products, and liquid properties
- Adjustable detection output delay prevents false detection in turbulent or splashing applications
- 'Fast Drip' fork design gives quicker response time when mounted horizontally, especially with viscous liquids
- A Media Learn function to ensure reliable detection even if the media characteristics are unknown
- Functionality is included for detecting sediment in a vessel

Contents

Ordering Information	page 4	Product Certifications	page 12
Spares and Accessories	page 8	Dimensional Drawings	page 15
Specifications	page 9		

FMEDA report

- IEC 61508 certified (SIL2), HFT = 0
- Safe Failure Fraction up to 97.7%
- Diagnostics coverage greater than 91%
- Dangerous Undetected Failure Rate = 13 (FIT) (when in a 'wet on' or 'dry on' configuration and the T1 terminal block is fitted)

For detailed Rosemount 2140:SIS failure rates, refer to the [FMEDA report](#).

Smart diagnostic suite

Frequency profiling

- Detects abnormal frequency deviations and responses from the fork sensor

Power advisory

- Detects abnormal deviations in the loop power through the device

Process alerts

- Set user-configurable alerts on HART variables

Applications

- Overfill prevention
- Automatic Overfill Prevention System (AOPS)
 - In an AOPS system, a Rosemount 2140:SIS high level alarm can be used as illustrated.
- High and low alarms
- Pump control or limit detection
- Run dry or pump protection
- Wet sediment build-up detection

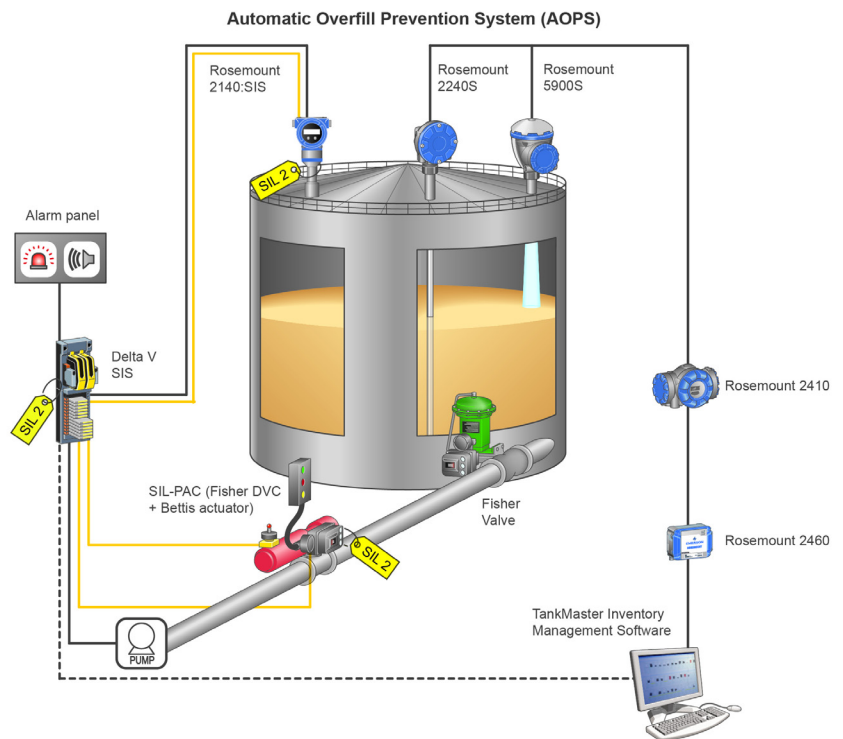
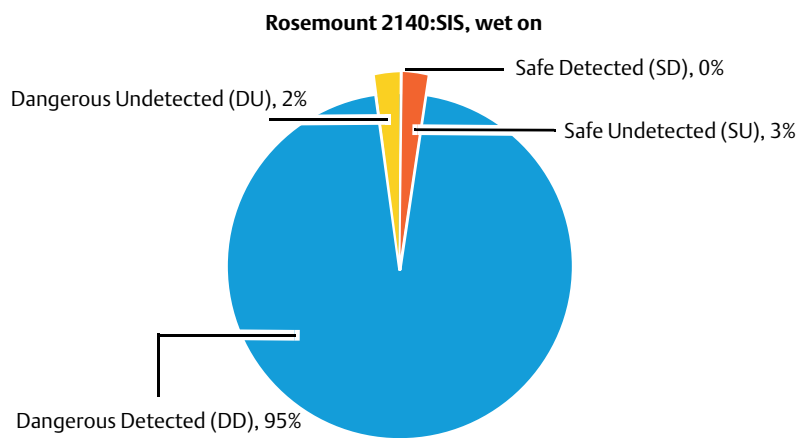
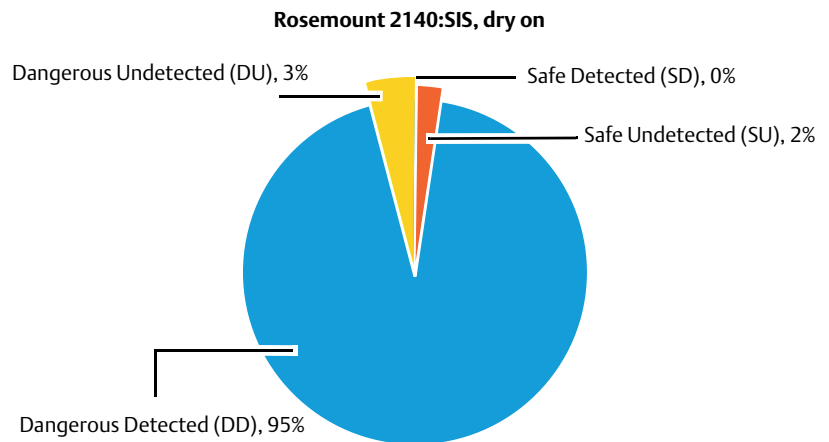

Ordering Information

Specification and selection of product materials, options, or components must be made by the purchaser of the equipment. See [page 10](#) for more information on Material Selection.

Table 1. Rosemount 2140 and 2140:SIS Ordering Information

The starred options (★) represent the most common options and should be selected for best delivery. The non-starred offerings are subject to additional delivery lead time.

Model	Product description		
2140	Vibrating Fork Liquid Level Detector		
Profile⁽¹⁾			
A	Standard monitoring and control application		★
F	Functional Safety / SIS applications		★
Output⁽²⁾			
H	mA output with HART communication		★
Housing material			
A	Aluminum alloy ASTM B85 A360.0		★
S	Stainless steel, 316C		★
Conduit entry / cable threads			
1	1/2-in. ANPT		★
2	M20		★
Operating temperature			
M	Mid-Range: -40 °F (-40 °C)... 356 °F (180 °C)		★
E	High: -94 °F (-70 °C)... 500 °F (260 °C)		★
Materials of construction: process connection / fork			
S	316/316L Stainless Steel (1.4401/1.4404)		★
F ⁽³⁾⁽⁵⁾	ECTFE copolymer, coated 316/316L SST (1.4401/1.4404)		
H	Alloy C (UNS N10002), Alloy C-276 (UNS N10276), Solid		
Process connection size		Available process connection	
9	3/4-in. / 19 mm	Thread	★
1	1-in. / 25 mm (DN25) / 25A	Thread, flange	★
2	2-in. / 50 mm (DN50) / 50A	Threaded, Flange, Tri Clamp	★
5	1 1/2-in. / 40 mm (DN40) / 40A	Flange, Tri Clamp	★
3	3-in. / 80 mm (DN80) / 80A	Flange	★
4	4-in. / 100 mm (DN100) / 100A	Flange	★
7	2 1/2-in. / 65 mm (DN65) / 65A	Flange	★
M	For use with Mobrey™ flange	Flange	★

Table 1. Rosemount 2140 and 2140:SIS Ordering Information

The starred options (★) represent the most common options and should be selected for best delivery. The non-starred offerings are subject to additional delivery lead time.

Process connection rating			
AA	ASME B16.5 Class 150 flange		★
AB	ASME B16.5 Class 300 flange		★
AC	ASME B16.5 Class 600 flange		★
DA	EN1092-1 PN 10/16 flange		★
DB	EN1092-1 PN 25/40 flange		★
DC	EN1092-1 PN 63 flange		★
DD	EN1092-1 PN 100 flange		★
JA	JIS B2220, 10K flange		★
JB	JIS B2220, 20K flange		★
MA	Mobrey A flange		★
MG	Mobrey G flange		★
NN	For use with non-flange process connection type		★
Process connection type			
R	Raised Face (RF) flange		★
M	Mobrey flange		★
B	BSPT (R) thread		★
G	BSPP (G) thread		★
N	NPT thread		★
P	BSPP (G), O-ring		★
C	Tri Clamp		★
Fork length		Available process connection	
A	Standard length 1.7 in. (44 mm)	All except flanged options	★
H ⁽⁴⁾	Standard length flange 4.0 in. (102 mm)	Flange	★
E ⁽⁵⁾	Extended, customer specified length in tenths of inches	All except 1-in. BSPP O-ring (1P)	★
M ⁽⁵⁾	Extended, customer specified length in millimeters	All except 1-in. BSPP O-ring (1P)	★
Specific extended fork length			
0000	Factory default length (only if Fork Length A or H is selected)		★
0060	6 inches extended length (only if Fork Length E is selected)	Best delivery (★) in North America.	
0090	9 inches extended length (only if Fork Length E is selected)	Best delivery (★) in North America.	
0120	12 inches extended length (only if Fork Length E is selected)	Best delivery (★) in North America.	
0240	24 inches extended length (only if Fork Length E is selected)	Best delivery (★) in North America.	
XXXX ⁽⁵⁾	Specific customer specified length in tenths of inches, or millimeters (XXX.X inches or XXXX) if code M or E is selected		★
Surface finish		Available process connection	
1	Standard surface finish	All	★
2	Mechanically polished (Ra < 0.1 μm)	Tri Clamp	★

Table 1. Rosemount 2140 and 2140:SIS Ordering Information

The starred options (★) represent the most common options and should be selected for best delivery. The non-starred offerings are subject to additional delivery lead time.

Product certifications		
NA ⁽⁶⁾	No hazardous locations certifications	★
ND	ATEX, Dust certification	★
E1 ⁽⁷⁾	ATEX Flameproof	★
E8	ATEX Flameproof and Dust	★
I1 ⁽⁷⁾	ATEX Intrinsic Safety and Dust	★
I8	ATEX Intrinsic Safety	★
K1	ATEX Intrinsic Safety, Flameproof, Dust	★
NK	IECEX, Dust certification	★
E7	IECEX Flameproof and Dust	★
I7	IECEX Intrinsic Safety	★
G5 ⁽⁸⁾	American Ordinary Locations (unclassified, safe area)	★
E5 ⁽⁸⁾	American Explosion-proof	★
I5	American Intrinsically Safe	★
K5	American Intrinsically Safe and Explosion-proof	★
G6 ⁽⁹⁾	Canadian Ordinary Locations (unclassified, safe area)	★
E6 ⁽⁹⁾	Canadian Explosion-proof	★
I6	Canadian Intrinsic Safety and Non-incendive	★
KB	American and Canadian, Explosion-proof, Intrinsically Safe, Non-Incendive	★
KZ	American and Canadian Ordinary location	★
GM	Technical Regulations Customs Union (EAC), Ordinary Location	★
EM	Technical Regulations Customs Union (EAC), Flameproof and Dust	★
IM	Technical Regulations Customs Union (EAC), Intrinsic Safety	★
E2	INMETRO, Flameproof	★
I2	INMETRO, Intrinsic Safety	★
E3	NEPSI, Flameproof	★
I3	NEPSI, Intrinsic Safety	★

Options (include with the selected model number)

Calibration data certification		
Q4	Certificate of functional test	★
Material traceability certification ⁽⁴⁾⁽¹⁰⁾		
Q8	Material traceability certification per EN 10204 3.1	★
Material certification ⁽⁴⁾⁽¹⁰⁾⁽¹¹⁾		
Q15	NACE [®] MR0175 / ISO 15156	★
Q25	NACE MR0103	★

Table 1. Rosemount 2140 and 2140:SIS Ordering Information

The starred options (★) represent the most common options and should be selected for best delivery. The non-starred offerings are subject to additional delivery lead time.

Terminal block		
T1	Transient protection terminal block	★
Display		
M4	LCD display with Local Operator Interface	★
Special procedures ⁽¹²⁾		
P1	Hydrostatic testing with certificate	★
Overfill prevention		
U1	WHG/DIBt Overfill Protection	
Alarm levels		
C4	Analog output levels compliant with NAMUR recommendation NE43, high alarm	★
C5	Analog output levels compliant with NAMUR recommendation NE43, low alarm	★
C1	Custom alarm and saturation signal levels (requires Configuration Data Sheet)	★
C8	Low alarm (standard Rosemount alarm and saturation levels)	★
HART revision configuration		
HR7	Device configured for HART 7 communication protocol	★
Safety certification ⁽¹³⁾		
QS	Prior-use certificate of FMEDA Data	★
QT ⁽¹⁴⁾	Safety certificate to IEC61508	★
Typical model number: 2140 A H A 1 M S 1 N N B A 0000 1 N A M4		

1. See [Table 2 on page 8](#) for available features when different Profile option codes are selected.
2. See [Table 5 on page 10](#) for available types of Current Output operation when different Profile option codes are selected.
3. ECTFE copolymer coating is only available for a flanged Rosemount 2140. Flanges are dual certified 316 and 316L Stainless Steel (1.4401 and 1.4404).
4. Not available for hand-polished process-wetted parts.
5. Minimum length available for ³/₄-in. threaded connection is 3.8 in. (95 mm); for 1-in. threaded, it is 3.7 in. (94 mm); for flanged, it is 3.5 in. (89 mm); and for Tri Clamp, it is 4.1 in. (105 mm). Maximum length is 157.5 in. (4000 mm), except for ECTFE copolymer coating and hand-polished process where the maximum length is 59.1 in. (1500 mm) and 39.4 in. (1000 mm) respectively. Examples: Code E1181 is 118.1 in. Code M3000 is 3000 mm.
6. Includes the Technical Regulation Customs Union (EAC) ordinary location mark.
7. Includes an Indian CCOE approval (see ["India approvals" on page 14](#)).
8. See ["Ordinary locations certifications" on page 12](#). E5 includes G5 requirements. G5 is for use in unclassified, safe area locations only.
9. See ["Ordinary locations certifications" on page 12](#). E6 includes G6 requirements. G6 is for use in unclassified, safe area locations only.
10. Only available for process-wetted parts.
11. Not available for code H (Alloy C/Alloy C-276) process-wetted parts.
12. Option limited to units with extended lengths up to 59.1-in. (1500 mm). Option is not available for ECTFE coating.
13. Only the Rosemount 2140:SIS is SIL2-certified.
14. The Rosemount 2140:SIS has been independently certified to IEC 61508 as required by IEC 61511. Certification was conducted by Exida. If documentation is required, add OPTION code "QT" to the end of the model number. One or more OPTION codes can be added at the end of the model number.

Table 2. Rosemount 2140 and 2140:SIS Profile Selection Features

Feature	Profile option code A	Profile option code F
Remote proof testing	Yes	Yes
Local proof testing (using test button)	Yes	Yes
Media learn	Yes	Yes
Frequency output	Yes	Yes
Sediment detection	Yes	No
Scaled variable	Yes	No
Smart diagnostic suite	Yes	Yes
HART 5 or HART 7	Yes	Yes

Spares and Accessories

Specification and selection of product materials, options, or components must be made by the purchaser of the equipment. See [page 10](#) for more information on Material Selection.

Table 3. Rosemount 2140 and 2140:SIS Spares and Accessories

The starred options (★) represent the most common options and should be selected for best delivery. The non-starred offerings are subject to additional delivery lead time.

Part number	Description	
02100-1000-0001	Seal for 1-in. BSPP (G1A). Material: Non-asbestos BS7531 grade X carbon fiber with rubber binder	★
02100-1040-0001	Seal for ³ / ₄ -in. BSPP (G3/4A). Material: Non-asbestos BS7531 grade X carbon fiber with rubber binder	★
02100-1010-0001	Adapter boss 1-in. BSPP to 1 ¹ / ₂ -in. (38 mm) Tri Clamp. Material: 316 SS fitting. FPM/FKM O-ring	★
02100-1020-0001	2-in. (51 mm) Tri Clamp kit (vessel fitting, clamp ring, and seal). Material: 316 SST NBR Nitrile	★
02100-1060-0001	Quick Release Kit (contains 2-in. Tri Clamp, seal, and quick release device for 2-in. NPT process connection)	★
02140-7000-0003	Spare kit. Standard Terminal Block (T0)	★
02140-7000-0004	Spare kit. Transient Protection Terminal (T1)	★

Specifications

General

Products

Rosemount 2140 Level Detector

Measuring technology

Vibrating fork

Applications

Most liquids including coating liquids, aerated liquids, and slurries.

Physical specifications

Material selection

Emerson provides a variety of Rosemount product with various product options and configurations including materials of construction that can be expected to perform well in a wide range of applications. The Rosemount product information presented is intended as a guide for the purchaser to make an appropriate selection for the application. It is the purchaser's sole responsibility to make a careful analysis of all process parameters (such as all chemical components, temperature, pressure, flow rate, abrasives, contaminants, etc.), when specifying product, materials, options and components for the particular application.

Emerson is not in a position to evaluate or guarantee the compatibility of the process fluid or other process parameters with the product, options, configuration or materials of construction selected.

Electronics housing

Materials

Aluminum alloy ASTM B85 A360.0 or stainless steel (316C)

Rotation

Rotatable housing to allow more convenient cable position.

Display

Optional two-line LCD display with Local Operator Interface (LOI). There are two internal and two external configuration buttons. Includes extended cover with glass window.

Local proof-test button

The Rosemount 2140 and 2140:SIS come with a single external button for local proof testing. This single button is replaced by two configuration buttons when the LCD display with LOI option is selected.

Note

Remote proof-testing is available using a HART command.

Conduit entries

Two M20 X 1.5 or 1/2-in ANPT conduit entries for cabling.

The Rosemount 2140 ships with dust caps installed in the conduit entries. One blanking plug is supplied in a plastic bag, ready to be installed. No cables or cable glands are supplied.

Ingress protection

IP66/67 to EN60529, NEMA® 4X (when supplied blanking plug and suitably rated cable glands are used).

Process-wetted connections

Connections

Threaded, Tri Clamp, and flanged process connection options. See [Table 1 on page 4](#) for a complete list.

Materials

316/316L Stainless Steel (1.4401/1.4404 dual-certified). Mechanically-polished option to better than 0.1 μm for Tri Clamp connections.

Alloy C (UNS N10002) and Alloy C-276 (UNS N10276) – available for flanged, and selected threaded process connections (3/4- and 1-in. BSPT (R), and 3/4- and 1-in. NPT).

ECTFE co-polymer coated 316/316L Stainless Steel (1.4401/1.4404 dual certified) – only available for a flanged Rosemount 2140 but excludes 1-in./DN25/25A flanges.

Gasket material for 3/4-in. and 1-in. BSPP (G) is non-asbestos BS 7531 Grade X carbon fiber with rubber binder. Gaskets are not supplied with flanged process connections.

Extended length options

The maximum extended length is 157.5 in. (4000 mm) except for ECTFE co-polymer coating and polished process connection options which have a maximum length of 59.1 in. (1500 mm) and 39.4 in. (1000 mm) respectively.

Table 4 has a summary of the minimum extended lengths. See “Dimensional Drawings” on page 15 for other dimensions.

Table 4. Minimum Extended Lengths

Process connection	Minimum extended length
3/4-in. threaded	3.8 in. (95 mm)
1-in. threaded	3.7 in. (94 mm)
2-in. threaded	3.7 in. (94 mm)
Flanged	3.5 in. (89 mm)
Tri Clamp	4.1 in. (105 mm)

Performance specifications

Hysteresis (water)

Approximately 0.1 in. (2.5 mm)

Detection point (water)

Approximately 0.5 in. (13 mm) from tip of fork (if vertical installation) or from edge of fork (if horizontal installation).

Detection points vary with different liquid densities. The level detectors allow pre-selection of a liquid density range, and have a built-in learning function to make it even easier.

Detection output delay

Optional output delay, programmable from 0 to 3600 seconds, to prevent false detection caused by splashing on the forks. Default delay is 1 second.

Liquid density ranges

There are four field-selectable density options for the level detector to use even more accurate detection points. The default pre-selection is Standard and is suitable for most liquids.

Low (400 to 600 kg/m³)

Medium (500 to 900 kg/m³)

Standard (800 to 1300 kg/m³)

High (1200 to 3000 kg/m³)

Liquid viscosity ranges

Up to 1000 cP (centiPoise) in Enhanced mode.

Up to 10000 cP (centiPoise) in Normal mode.

Electrical specifications

Power supply

10.5 to 42.4 Vdc (with no load).

Output

Table 5. Current Output Availability with Profile Option Codes A (Rosemount 2140) and F (Rosemount 2140:SiS)

Current Output operating types ⁽¹⁾	Profile option code A	Profile option code F
8/16 mA HART switched output	Yes	Yes
4/20 mA HART switched output	Yes	Yes
Custom mA HART switched output	Yes	Yes
4–20 mA HART	Yes	No
LEVELTESTER switched output	Yes	Yes

1. Software selectable.

Digital process variable is superimposed on 4–20 mA signal, available to any host that conforms to HART protocol.

Selectable digital HART revisions, HART5 (default) or HART7. The revision can be switched using any HART-based configuration tool or the optional local operator interface.

Grounding

The Rosemount 2140 must always be grounded through either the internal or external ground connections provided.

Terminal connections (wire diameter)

Minimum 24 AWG and maximum 14 AWG (0.2 to 2.5 mm²)

Environmental specifications

Maximum operating pressures

The final rating depends on the process-wetted connection.

- Threaded connection:
see [Figure 1 on page 11](#) for operating pressures.
- Tri Clamp connection: 435 psig (30 bar g).
- Flanged connection:
see [Figure 1](#) or [Table 6 on page 11](#)
(whichever gives the lowest pressure).

Figure 1. Operating Pressures

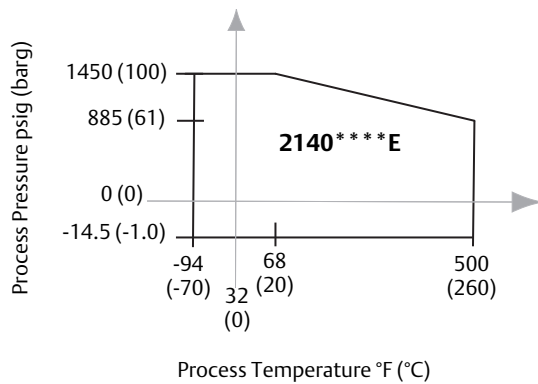
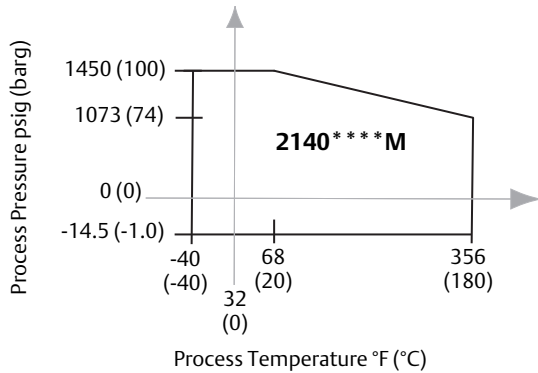

Table 6. Maximum Flange Pressure Rating

Standard	Class/rating	Stainless steel flanges
ASME B16.5	Class 150	275 psig ⁽¹⁾
ASME B16.5	Class 300	720 psig ⁽¹⁾
ASME B16.5	Class 600	1,440 psig ⁽¹⁾
EN1092-1	PN 10/16	16 barg ⁽²⁾
EN1092-1	PN 25/40	40 barg ⁽²⁾
EN1092-1	PN 63	63 barg ⁽²⁾
EN1092-1	PN 100	100 barg ⁽²⁾
JIS B2220	10K	14 barg ⁽³⁾
JIS B2220	20K	34 barg ⁽³⁾
Mobrey A flange	Not applicable	33 bar
Mobrey G flange	Not applicable	21 bar

- At 100 °F (38 °C), the pressure rating decreases with an increasing process temperature.
- At 122 °F (50 °C), the pressure rating decreases with an increasing process temperature.
- At 248 °F (120 °C), the rating decreases with an increasing process temperature.

Ambient temperature limits

-40 to 175 °F (-40 to 80 °C) with or without the LOI display

See also “Product Certifications” on page 12 for the reduced ambient temperature limits required by approvals.

Minimum and maximum operating temperatures

See Figure 2 for operating temperatures.

Check “Product Certifications” on page 12 for operating temperature limits required by approvals.

Figure 2. Operating Temperatures

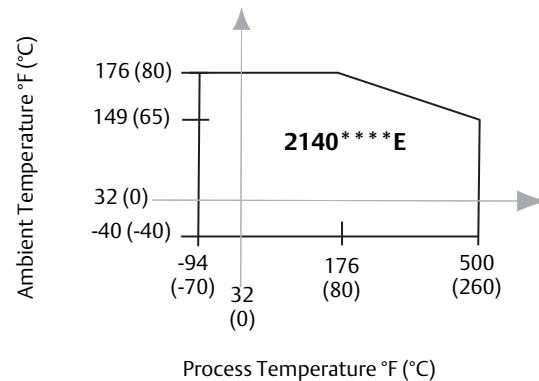
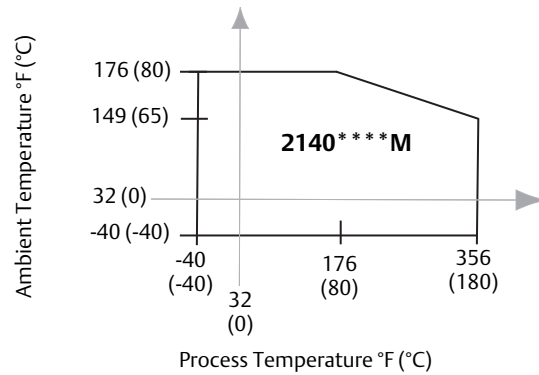

Product Certifications

Note

For full product approvals information, refer to the Rosemount 2140 [Product Certifications Manual](#).

European Union directive information

A copy of the EU Declaration of Conformity can be found at the end of the Rosemount 2140 [Product Certifications Manual](#) and at Emerson.com/Rosemount.

NAMUR approval

NAMUR NE95 type test report is available upon request. Complies with NAMUR NE21.

Overfill approval

TUV-tested and approved for overfill protection according to the German DiBt/WHG regulations. Certified under safety devices for tanks and piping related to water pollution control.

Ordinary locations certifications

G5 USA Ordinary Location

Certificate: 16 CSA 70098390

Standard:
UL 61010-1: 2012

The level detector has been examined and tested to determine that the design meets basic electrical, mechanical, and fire protection requirements by CSA, a nationally recognized testing laboratory (NRTL) as accredited by the Federal Occupational Safety and Health Administration (OSHA).

Type 4X.

G6 Canada Ordinary Location

Certificate: 16 CSA 70098390

Standards:
CAN/CSA C22.2 No 61010-1-12
ANSI/ISA-12.27.01:2011

The level detector has been examined and tested to determine that the design meets basic electrical, mechanical, and fire protection requirements by CSA, a nationally recognized testing laboratory as accredited by the Standards Council of Canada (SCC).

Type 4X. Single Seal.

Canadian Registration Number

Certificate: CRN 0F04227.2C

Standards:
ASME B31.3:2014
ASME B16.5:2013

The requirements of CRN are met when a Rosemount 2140 Level Detector is configured with 316/316L stainless steel (1.4401/1.4404) process-wetted parts and either NPT threaded or 2 to 8-in. ASME B16.5 flanged process connections.

Hazardous locations certifications

North America and Canada

E5 USA Explosion-proof and Division 2 (XP)

Certificate: CSA 16CA70098390X

Standards:
FM Class 3600 - 2011
FM Class 3615 - 2015
UL 61010-1: 2012

Markings:
Class I Groups B, C and D, T6...T2
Class 1 Division 2 Groups A, B, C, and D, Type 4X
Class I, Zone 1, AEx db IIC T6...T2 Gb

E6 Canada Explosion-proof and Division 2 (XP)

Certificate: CSA 16CA70098390X

Standards:
ANSI/ISA 12.27.01:2011
CSA Std. C22.2 No. 30 -M1986
CSA Std. C22.2 No.60079-0-15
CSA Std. C22.2. No.60079-1-16
CSA Std. C22.2 No. 61010-1-12
CSA Std. C22.2 No.94-M91
CSA Std. C22.2 No. 213-2016

Markings:
Class I Groups B, C and D, T6...T2
Class 1 Division 2 Groups A, B, C, and D, Type 4X
Ex db IIC T6...T2 Gb, single seal

I5 USA Intrinsic Safety (IS) and Non-Incendive (NI)

Certificate: CSA 16CA70098390X

Standards:
FM Class 3600 - 2011
FM Class 3610 - 2015
FM Class 3611 - 2004

Markings:
Class I Groups A, B, C and D, T5...T2
Class I, Division 2, Groups A, B, C, and D, Type 4X
Class I, Zone 0, AEx ia IIC T5...T2 Ga
when connected using installation drawing 71097/1387

- I6** Canada Intrinsic Safety and Non-Incendive
 Certificate: CSA 16CA70098390X
 Standards:
 ANSI/ISA 12.27.01:2011
 CSA Std. C22.2 No. 157 -92
 CSA Std. C22.2 No.60079-0-15
 CSA Std. C22.2. No.60079-11-14
 Markings:
 Class I Groups A, B, C and D, T5...T2
 Class I, Division 2, Groups A, B, C, and D, Type 4X
 Ex ia IIC T5...T2 Ga, single seal
 when connected using installation drawing 71097/1387

Europe

- E1** ATEX Flameproof
 Certificate: Dekra 16ATEX0082X
 Standards:
 EN60079-0:2012+A11:2013
 EN60079-1:2014
 EN60079-26:2015
 Markings:
 Ⓢ II 1/2 G, Ex db IIC T6...T2 Ga/Gb
- ND** ATEX Dust
 Certificate: Baseefa 16ATEX0137X
 Standards:
 EN60079-0:2012+A11:2013
 EN60079-31:2014
 Markings:
 Ⓢ II 1 D, Ex ta IIIC
 (T92°C...T272°C) (T₅₀₀100°C...T₅₀₀280°C) Da
- E8** Combines **E1** and **ND**
- I1** ATEX Intrinsically Safe and Dust (Zone 0, 20)
 Certificates:
 Baseefa 16ATEX0136X and Baseefa 16ATEX0137X
 Standards:
 EN60079-0:2012+A11:2013
 EN60079-11:2012
 EN60079-26:2015
 EN60079-31:2014
 Markings:
 Ⓢ II 1 G, Ex ia IIC T5...T2 Ga
 Ⓢ II 1 D Ex ta IIIC
 (T92...T272°C) (T₅₀₀100°C...T₅₀₀280°C) Da
 (**I1** includes the **ND** approval)
- I8** ATEX Intrinsically Safe (Zone 1)
 Certificate: Baseefa 16ATEX0136X
 Standards:
 EN60079-0:2012+A11:2013
 EN60079-11:2012
 EN60079-26:2015
 Markings: Ⓢ II 1/2 G, Ex ia IIC T5...T2 Ga/Gb

International

- E7** IECEx Flameproof and Dust
 Certificates: IECEx DEK 16.0040X and IECEx BAS 16.0106X
 Standards:
 IEC60079-0:2011
 IEC60079-1:2014
 IEC60079-26:2014
 IEC60079-31:2013
 Markings:
 Ex db IIC T6...T2 Ga/Gb
 Ex ta IIIC (T92°C...T272°C) (T₅₀₀100°C...T₅₀₀280°C) Da
 (**E7** also includes the **NK** approval)
- I7** IECEx Intrinsically Safe
 Certificate: IECEx BAS 16.0105X
 Standards:
 IEC60079-0:2011
 IEC60079-11:2011
 Markings:
 Ex ia IIC T5...T2 Ga
- NK** IECEx Dust
 Certificate: IECEx BAS 16.0106X
 Standards:
 IEC60079-0:2011
 IEC60079-31:2013
 Markings:
 Ex ta IIIC (T92°C...T272°C) (T₅₀₀100°C...T₅₀₀280°C) Da

Combinations of approvals

- K1** Combines **I1** and **E1**
K5 Combines **I5** and **E5**
KB Combines **I5**, **I6**, **E5**, and **E6**
KZ Combines **G5** and **G6**

Brazil approvals

- E2** INMETRO Flameproof
 Certificate: UL-BR 017.0843X
 Standards:
 ANBT NBR IEC 60079-0:2013
 ABNT NBR IEC 60079-1:2016
 ABNT NBR IEC 60079-26:2016
 Markings: Ex db IIC T6...T2 Ga/Gb
- I2** INMETRO Intrinsic Safety
 Certificate: UL-BR 17.0837X
 Standards:
 ANBT NBR IEC 60079-0:2013
 ABNT NBR IEC 60079-11:2013
 Markings: Ex ia IIC T5...T2 Ga

China approvals

E3 China Flameproof and Dust

Certificate: GYJ17.1508X

Standards:

GB 3836.1-2010

GB 3836.2-2010

GB 3836.20-2010

GB 12476.1-2013

GB 12476.5-2013

Markings:

Ex db IIC T6~T2 Ga/Gb

Ex ta IIIC (T92 °C~T272 °C) (T₅₀₀100 °C~T₅₀₀280 °C) Da

I3 China Intrinsic Safety

Certificate: GYJ17.1498X

Standards:

GB 3836.1-2010

GB 3836.4-2010

GB 3836.20-2010

Markings:

Ex ia IIC T5~T2 Ga

Russia approvals

EM Technical Regulation Customs Union (EAC) Flameproof and Dust

Certificate: TC RU C-GB.AA87.B.00728

Markings:

Ex db IIC T6...T2 X

Ex ta IIIC T92 °C...T272 °C T₅₀₀100°C...T₅₀₀280 °C Da X

IM Technical Regulation Customs Union (EAC) Intrinsic Safety

Certificate:

TC RU C-GB.AA87.B.00728

Markings:

OEx ia IIC T5...T2 Ga X

India approvals

E1 CCOE Flameproof

Certificate: P408160/1

Standards:

EN60079-0:2012+A11:2013

EN60079-1:2014

EN60079-26:2015

Markings: Ex db IIC T6...T2 Ga/Gb

I1 CCOE Intrinsic Safety

Certificate: P408161/1

Standards:

EN60079-0:2012+A11:2013

EN60079-11:2012

EN60079-26:2015

Markings: Ex ia IIC T5...T2 Ga

Dimensional Drawings

Figure 3. 3/4- and 1-in. Threaded Process Connection (Mid Temperature Range, Standard Length Fork)

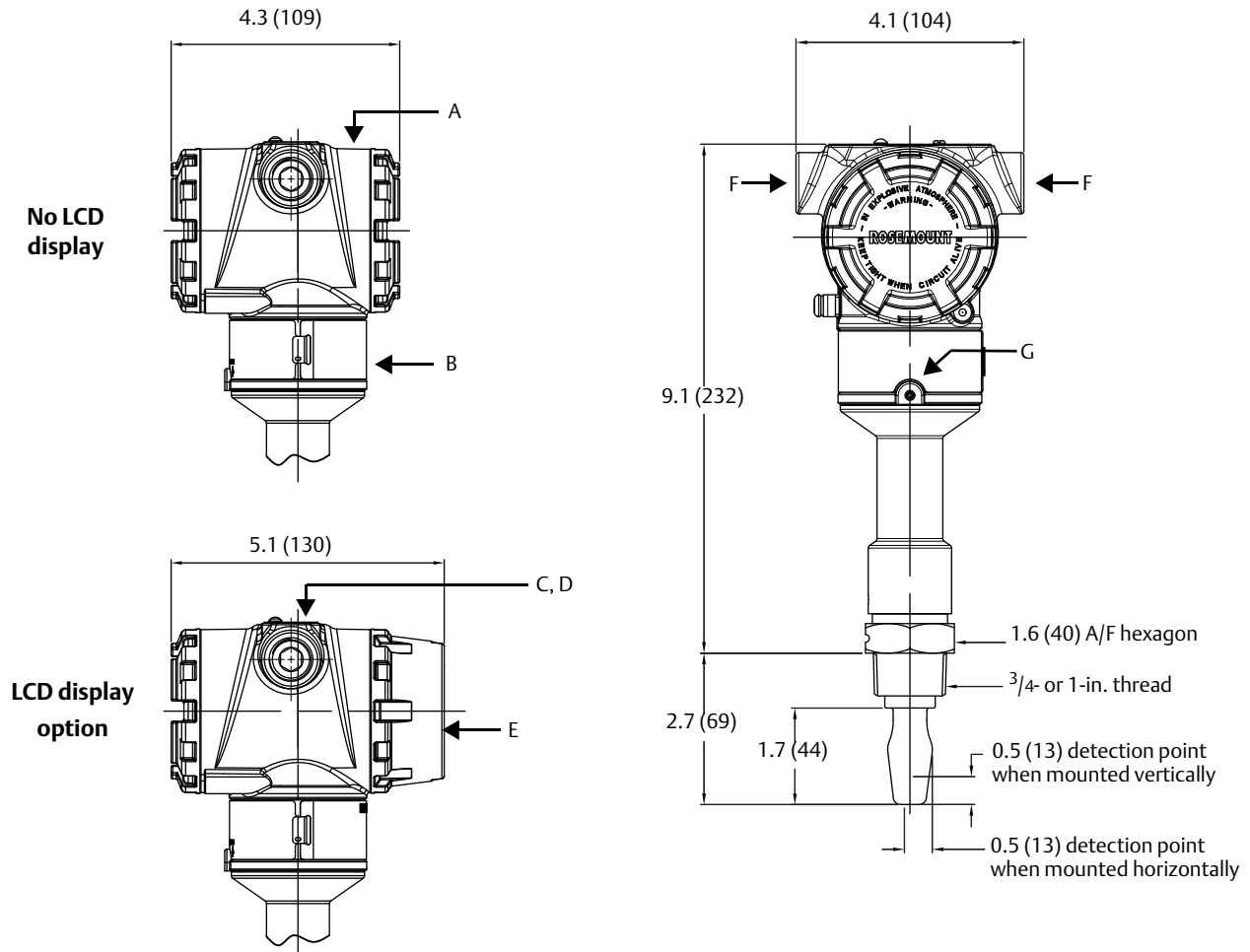

- A. Aluminum or stainless steel housing
- B. Certification plate
- C. Cover plate (with logo, product name, and conduit entry size)
- D. External button(s) under movable plate
- E. LCD display cover

- F. Conduit/cable entry M20 x 1.5 or 1/2-in. ANPT
- G. Housing rotation set screw. Do not unscrew all the way. Rotating the housing, without this screw in place, can damage the internal wiring

Dimensions are in inches (mm).

Figure 4. 3/4- and 1-in. Threaded Process Connection (Mid Temperature Range, Extended Length Fork)

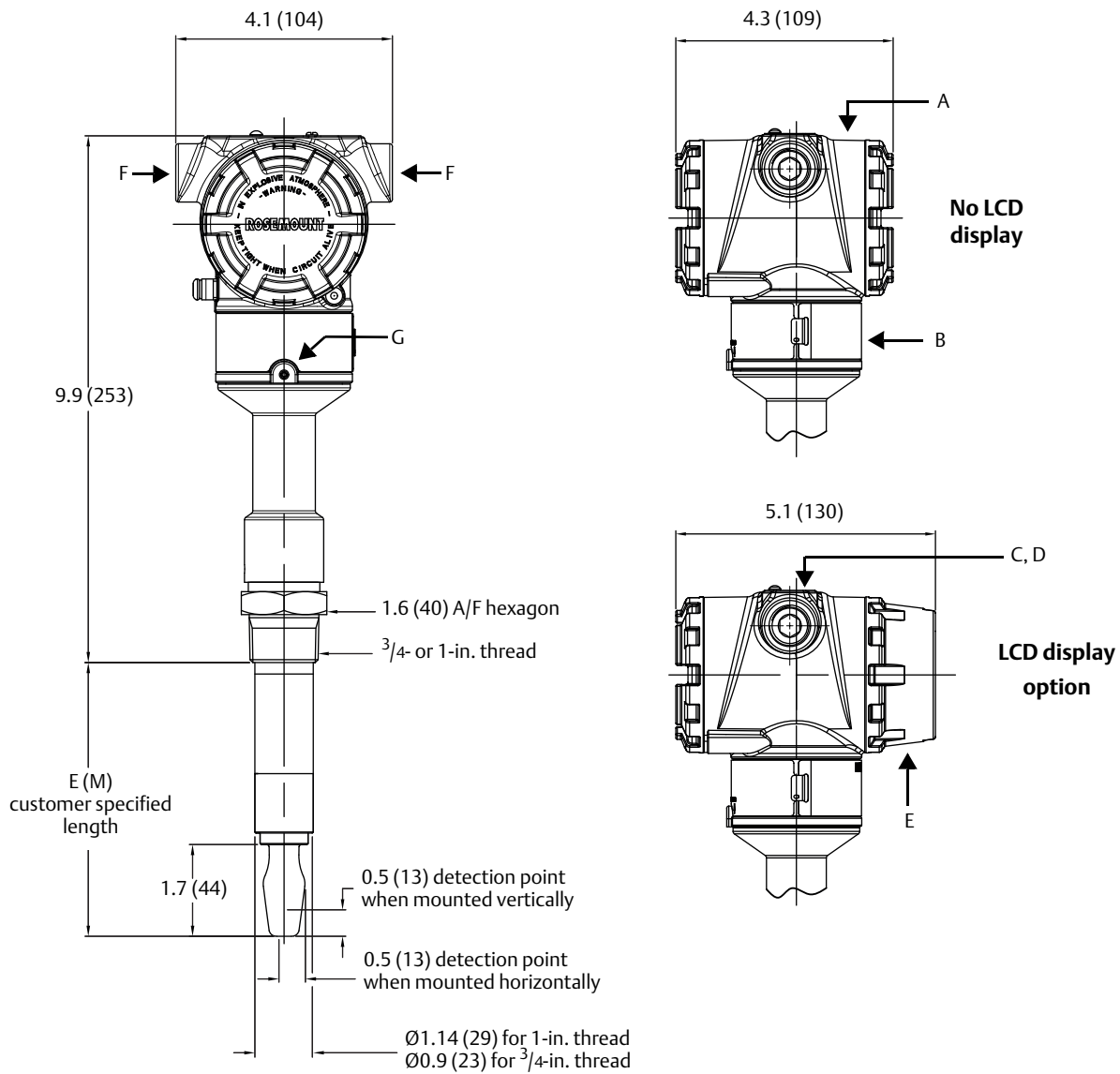

- A. Aluminum or stainless steel housing
 - B. Certification plate
 - C. Cover plate (with logo, product name, and conduit entry size)
 - D. External button(s) under movable plate
 - E. LCD display cover
 - F. Conduit/cable entry M20 x 1.5 or 1/2-in. ANPT
 - G. Housing rotation set screw. Do not unscrew all the way. Rotating the housing, without this screw in place, can damage the internal wiring
- Dimensions are in inches (mm).

Table 7. Fork Length for 3/4- and 1-in. Threaded Rosemount 2140

Process connection	Standard length fork length code A	Minimum length fork length code E (M)	Maximum length fork length code E (M)
3/4-in. thread	1.7 in. (44 mm)	3.75 in. (95 mm)	157.5 in. (4000 mm)
1-in. thread	1.7 in. (44 mm)	3.74 in. (94 mm)	157.5 in. (4000 mm)

Figure 5. 3/4- and 1-in. Threaded Process Connection (High Temperature Range, All Fork Lengths)

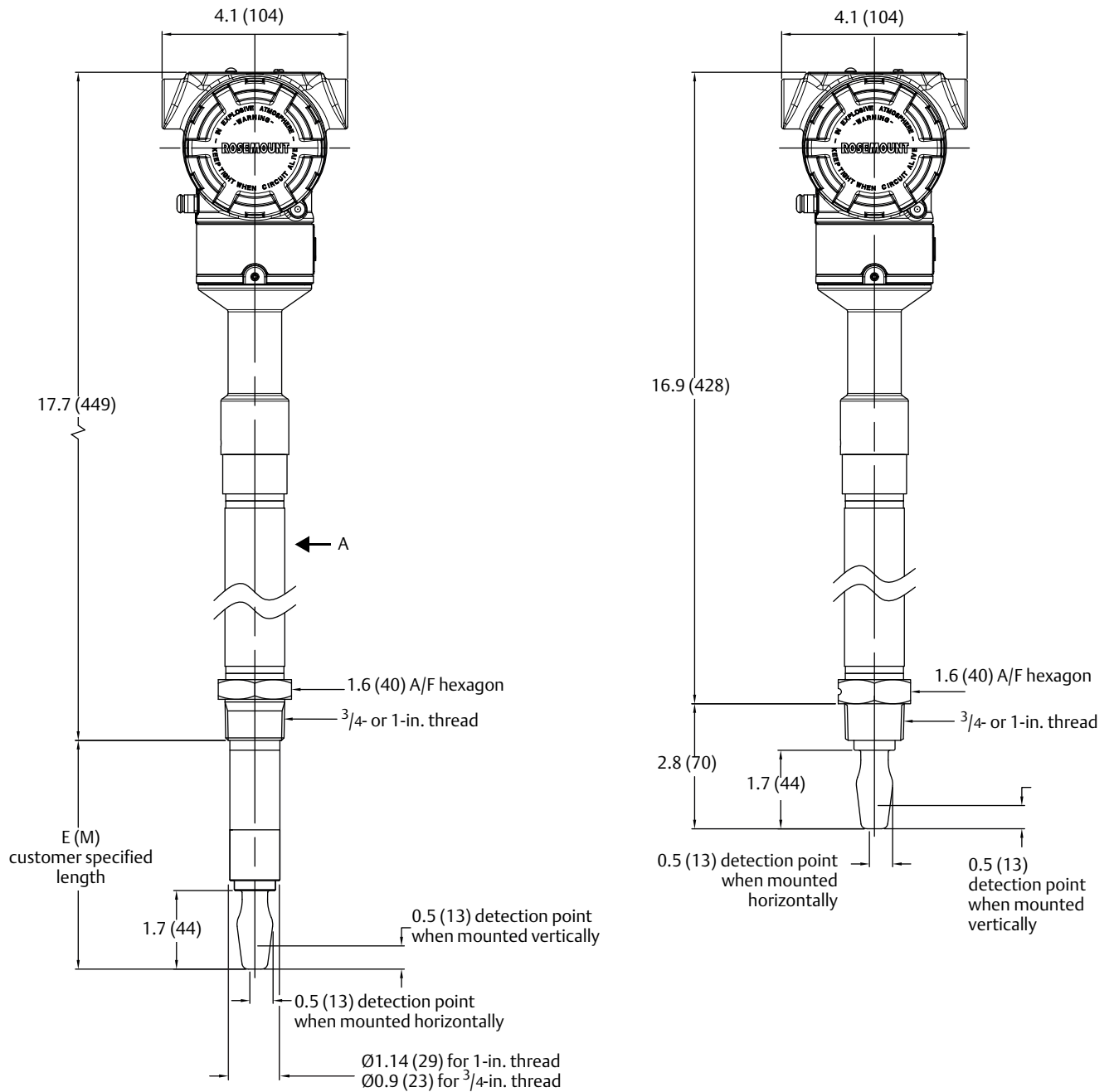

A. Thermal tube.

Dimensions are in inches (mm).

For dimensions and features not shown here, see [Figure 4 on page 16](#).

Figure 6. 2-in. Threaded Process Connection (Mid Temperature Range, Standard Length Fork)

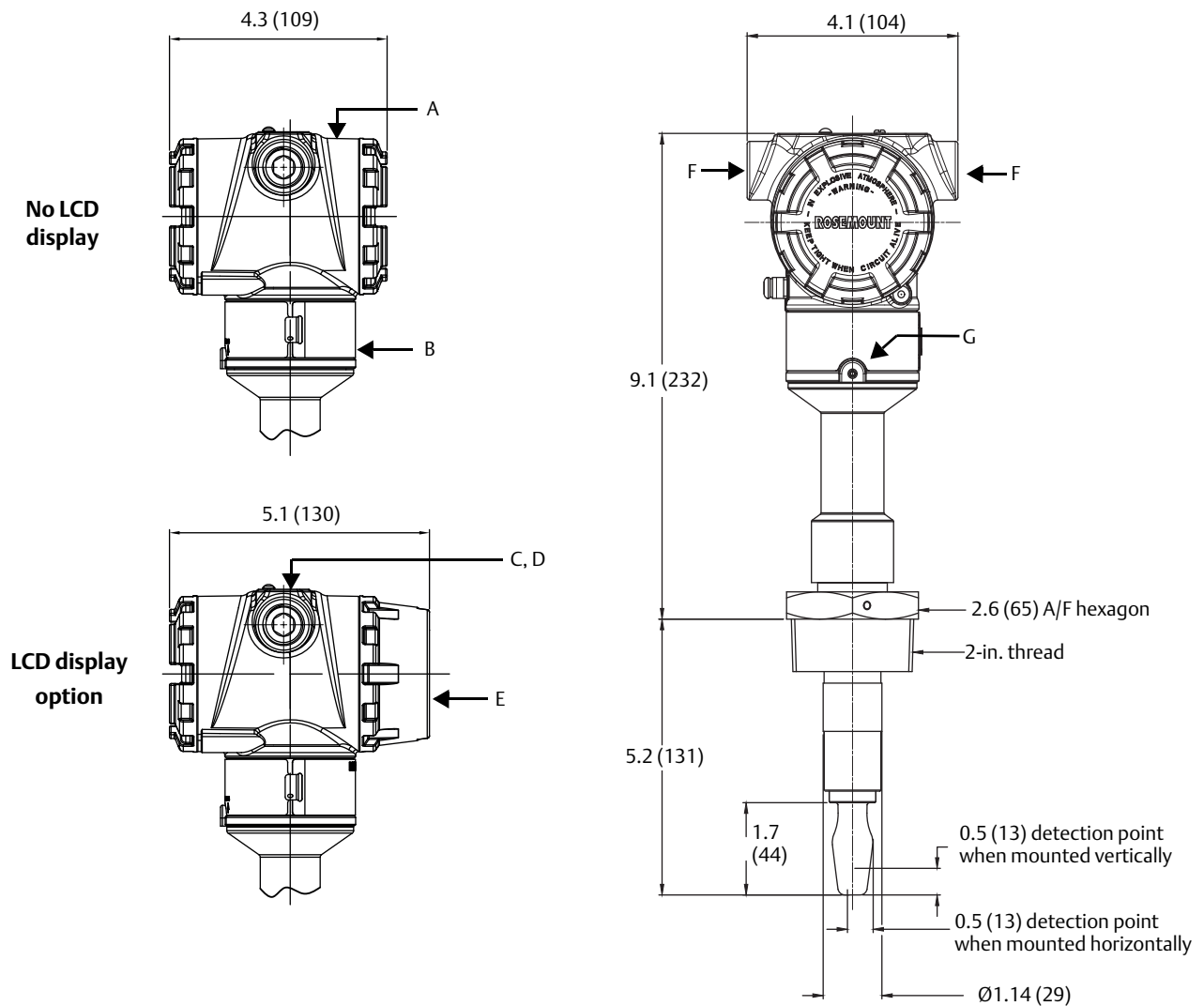

- A. Aluminum or stainless steel housing
- B. Certification plate
- C. Cover plate (with logo, product name, and conduit entry size)
- D. External button(s) under movable plate
- E. LCD display cover

- F. Conduit/cable entry M20 x 1.5 or 1/2-in. ANPT
- G. Housing rotation set screw. Do not unscrew all the way. Rotating the housing, without this screw in place, can damage the internal wiring

Dimensions are in inches (mm).

Figure 7. 2-in. Threaded Process Connection (Mid Temperature Range, Extended Length Fork)

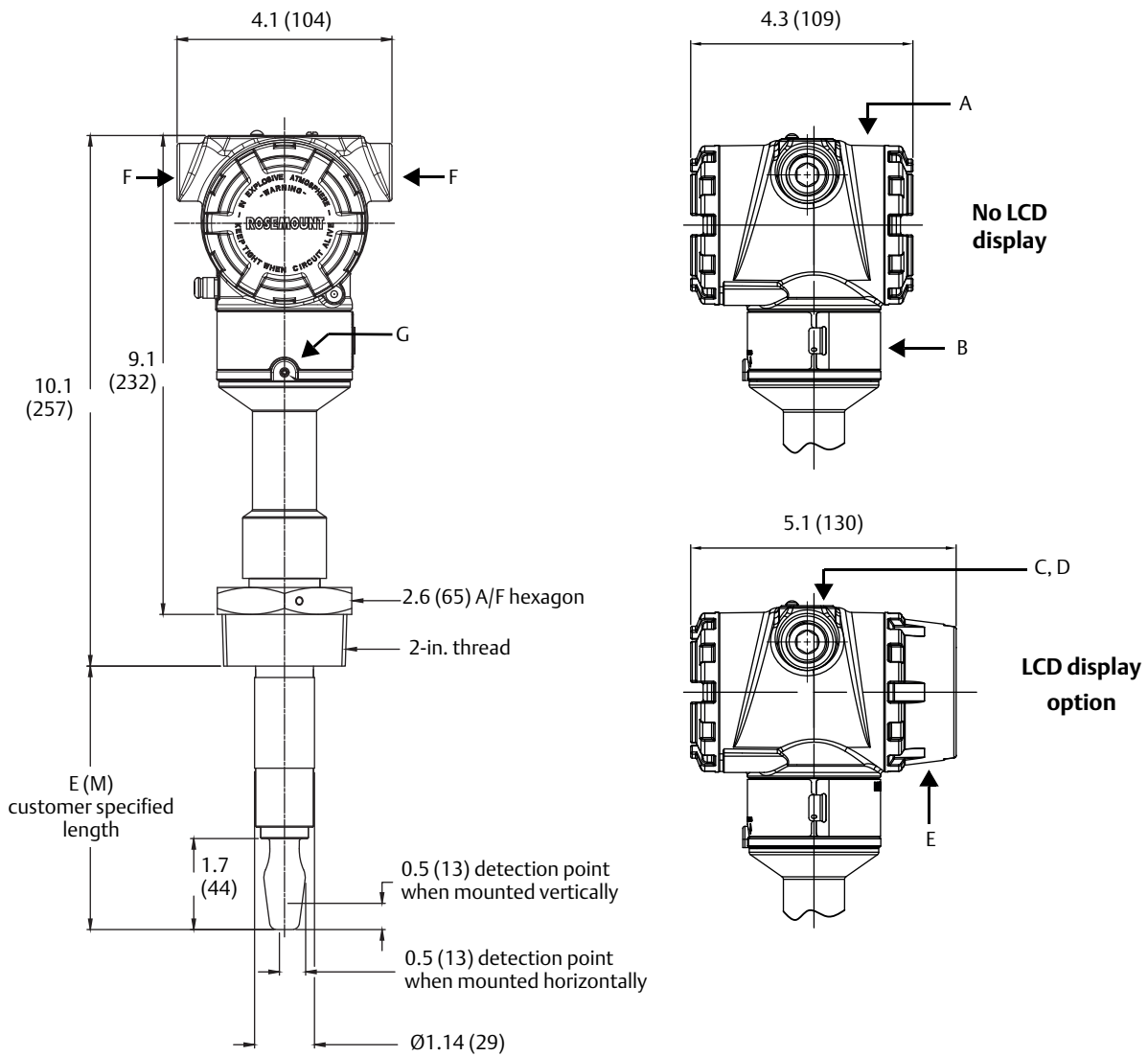

- A. Aluminum or stainless steel housing
 - B. Certification plate
 - C. Cover plate (with logo, product name, and conduit entry size)
 - D. External button(s) under movable plate
 - E. LCD display cover
 - F. Conduit/cable entry M20 x 1.5 or 1/2-in. ANPT
 - G. Housing rotation set screw. Do not unscrew all the way. Rotating the housing, without this screw in place, can damage the internal wiring
- Dimensions are in inches (mm).

Table 8. Fork Length for 2-in. Threaded Rosemount 2140

Process connection	Standard length fork length code A	Minimum length fork length code E (M)	Maximum length fork length code E (M)
2-in. thread	1.7 in. (44 mm)	3.74 in. (94 mm)	157.5 in. (4000 mm)

Figure 8. Tri Clamp Process Connection (Mid Temperature Range, Standard Length Fork)

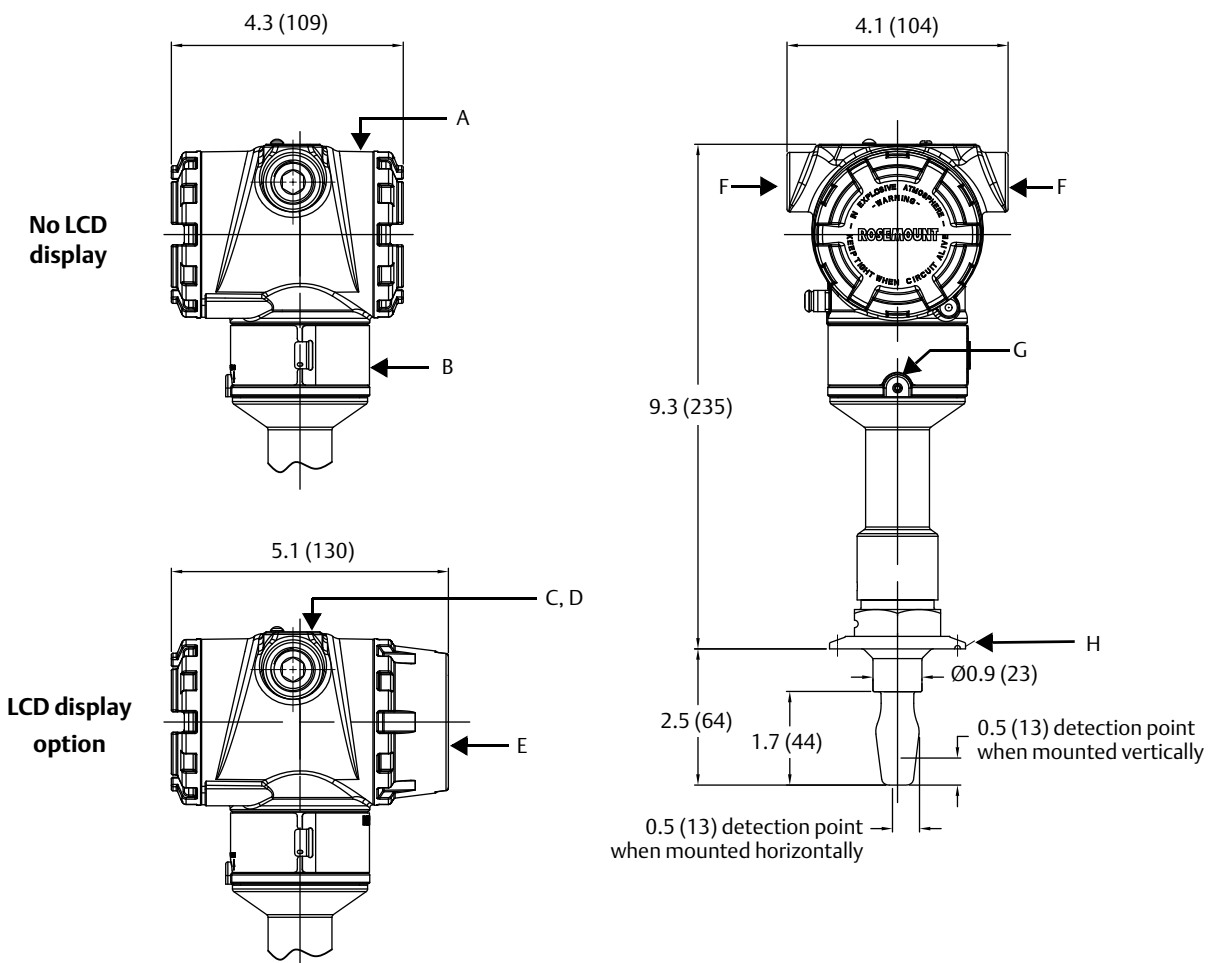

- A. Aluminum or stainless steel housing
- B. Certification plate
- C. Cover plate (with logo, product name, and conduit entry size)
- D. External button(s) under movable plate
- E. LCD display cover

- F. Conduit/cable entry M20 x 1.5 or 1/2-in. ANPT
- G. Housing rotation set screw. Do not unscrew all the way. Rotating the housing, without this screw in place, can damage the internal wiring
- H. 1 1/2- or 2-in. Tri Clamp

Dimensions are in inches (mm)

Figure 9. Tri Clamp Process Connection (Mid Temperature Range, Extended Length Fork)

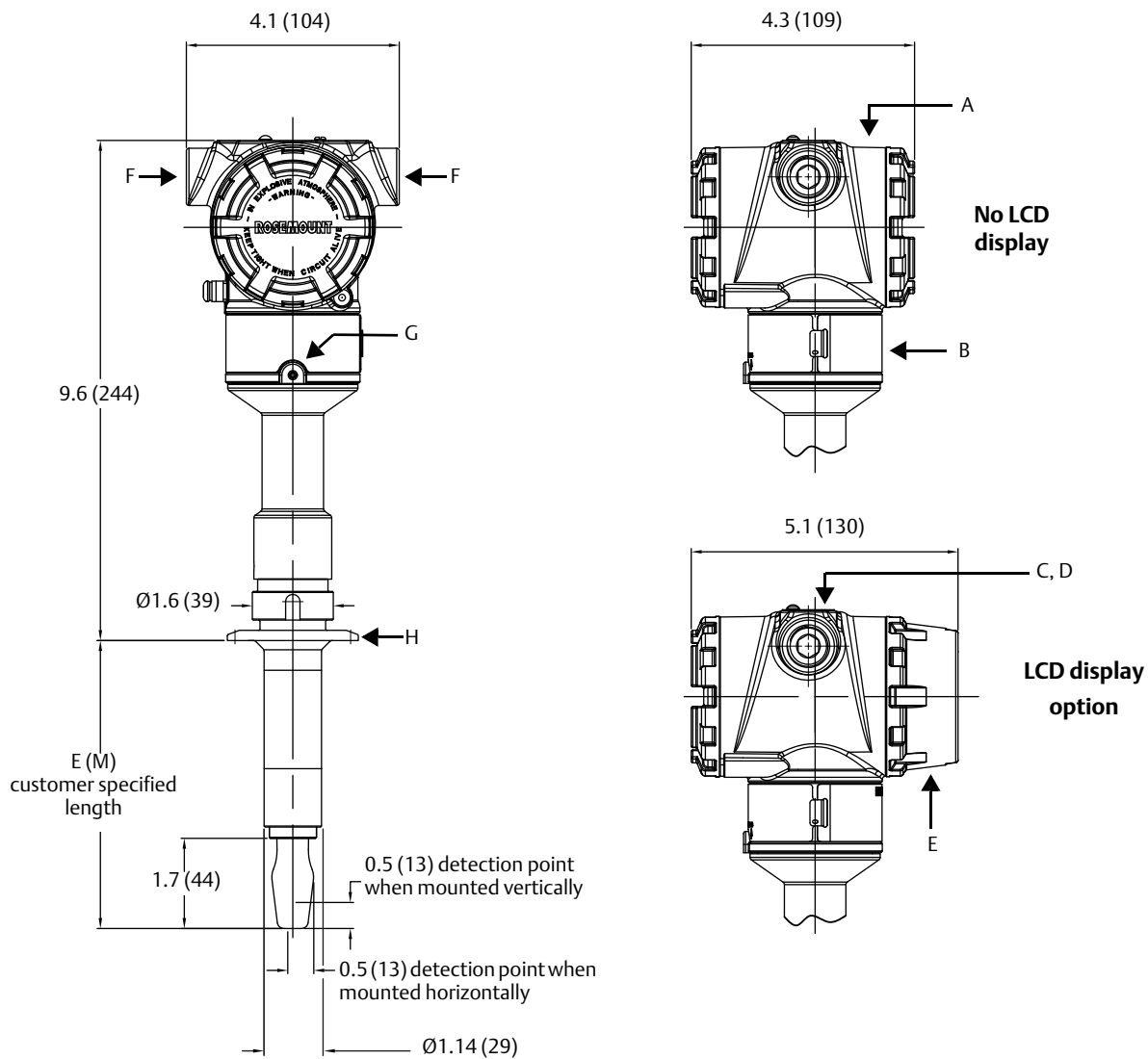

- A. Aluminum or stainless steel housing
 - B. Certification plate
 - C. Cover plate (with logo, product name, and conduit entry size)
 - D. External button(s) under movable plate
 - E. LCD display cover
 - F. Conduit/cable entry M20 x 1.5 or 1/2-in. ANPT
 - G. Housing rotation set screw. Do not unscrew all the way. Rotating the housing, without this screw in place, can damage the internal wiring
 - H. 1 1/2- or 2-in. Tri Clamp
- Dimensions are in inches (mm).

Table 9. Fork Length for Hygienic Rosemount 2140

Process connection	Standard length fork length code A	Minimum length fork length code E (M)	Maximum length fork length code E (M)
Tri Clamp	1.7 in. (44 mm)	4.13 in. (105 mm)	157.5 in. (4000 mm)
O-ring seal (1-in. BSPP) ⁽¹⁾	1.7 in. (44 mm)	4.13 in. (105 mm)	38.4 in. (1000 mm)

1. For these dimension drawings, refer to the Rosemount 2140 Type 1 drawings at Emerson.com/Rosemount.

Figure 10. Tri Clamp Process Connection (High Temperature Range, All Fork Lengths)

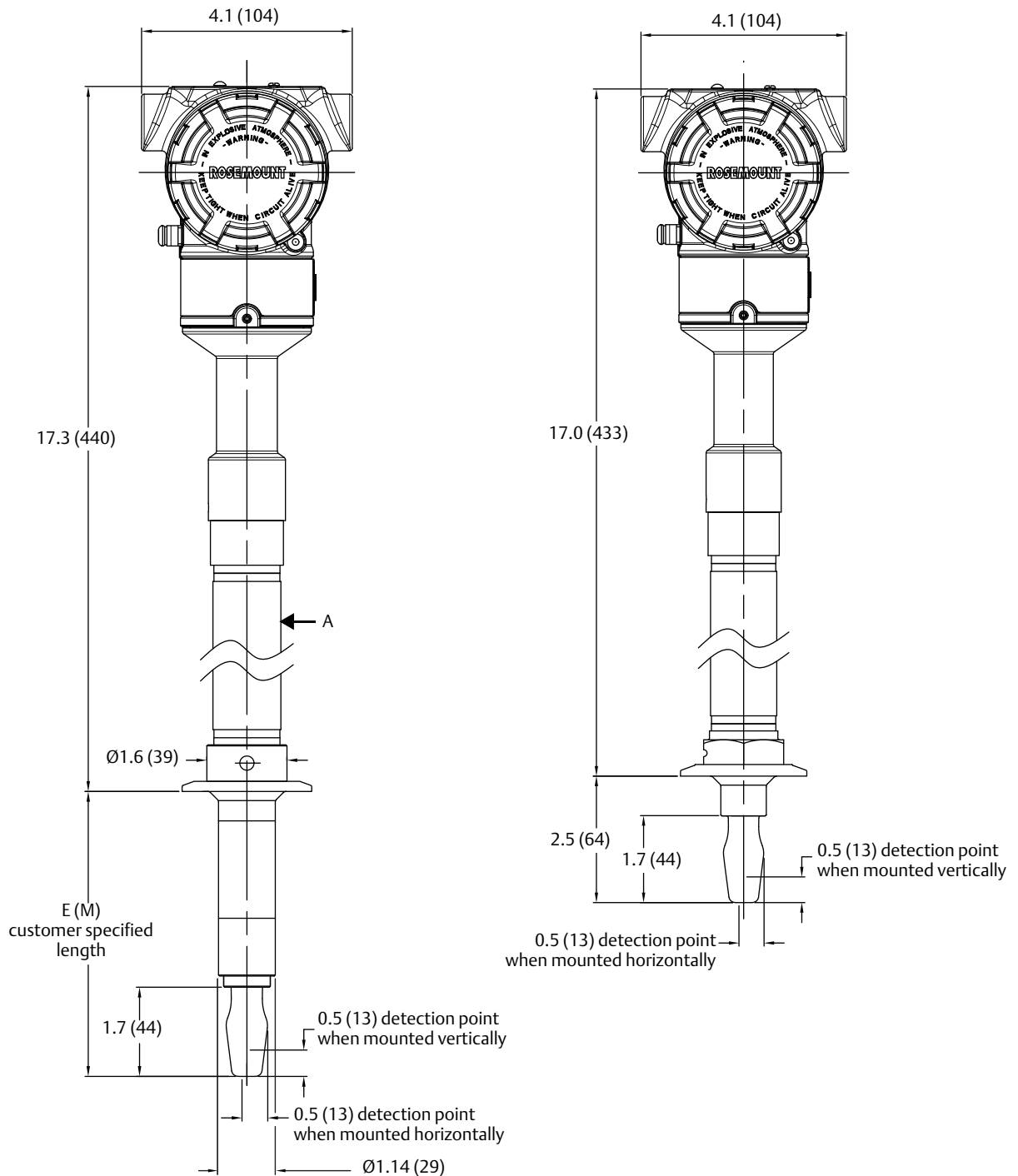

A. Thermal tube.

Dimensions are in inches (mm).

For dimensions and features not shown here, see [Figure 9 on page 21](#).

Figure 11. Flanged Process Connection (Mid Temperature Range, Standard Length Fork)

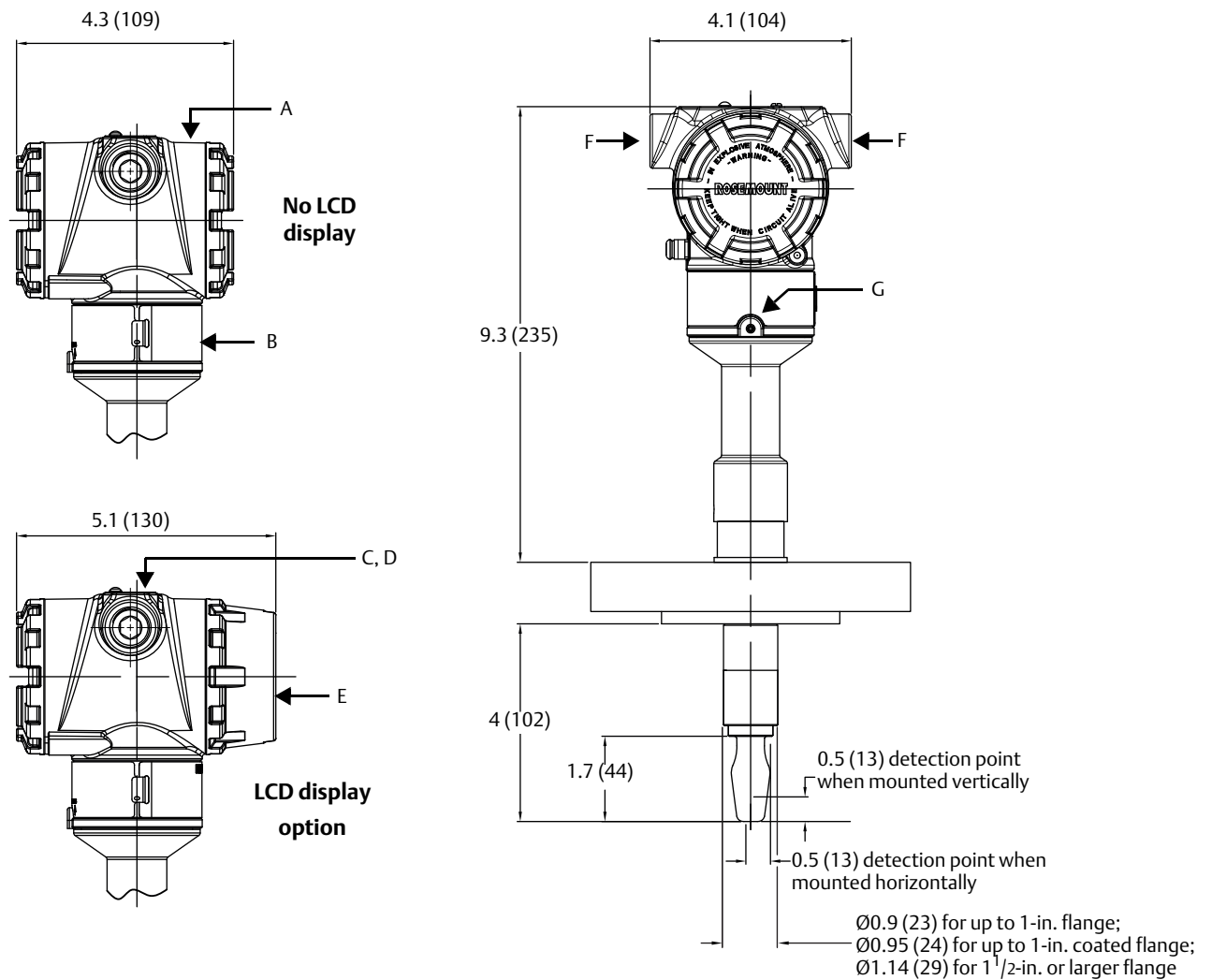

- A. Aluminum or stainless steel housing
- B. Certification plate
- C. Cover plate (with logo, product name, and conduit entry size)
- D. External button(s) under movable plate
- E. LCD display cover
- F. Conduit/cable entry M20 x 1.5 or 1/2-in. ANPT
- G. Housing rotation set screw. Do not unscrew all the way. Rotating the housing, without this screw in place, can damage the internal wiring

Dimensions are in inches (mm).

Figure 12. Flanged Process Connection (Mid Temperature Range, Extended Length Fork)

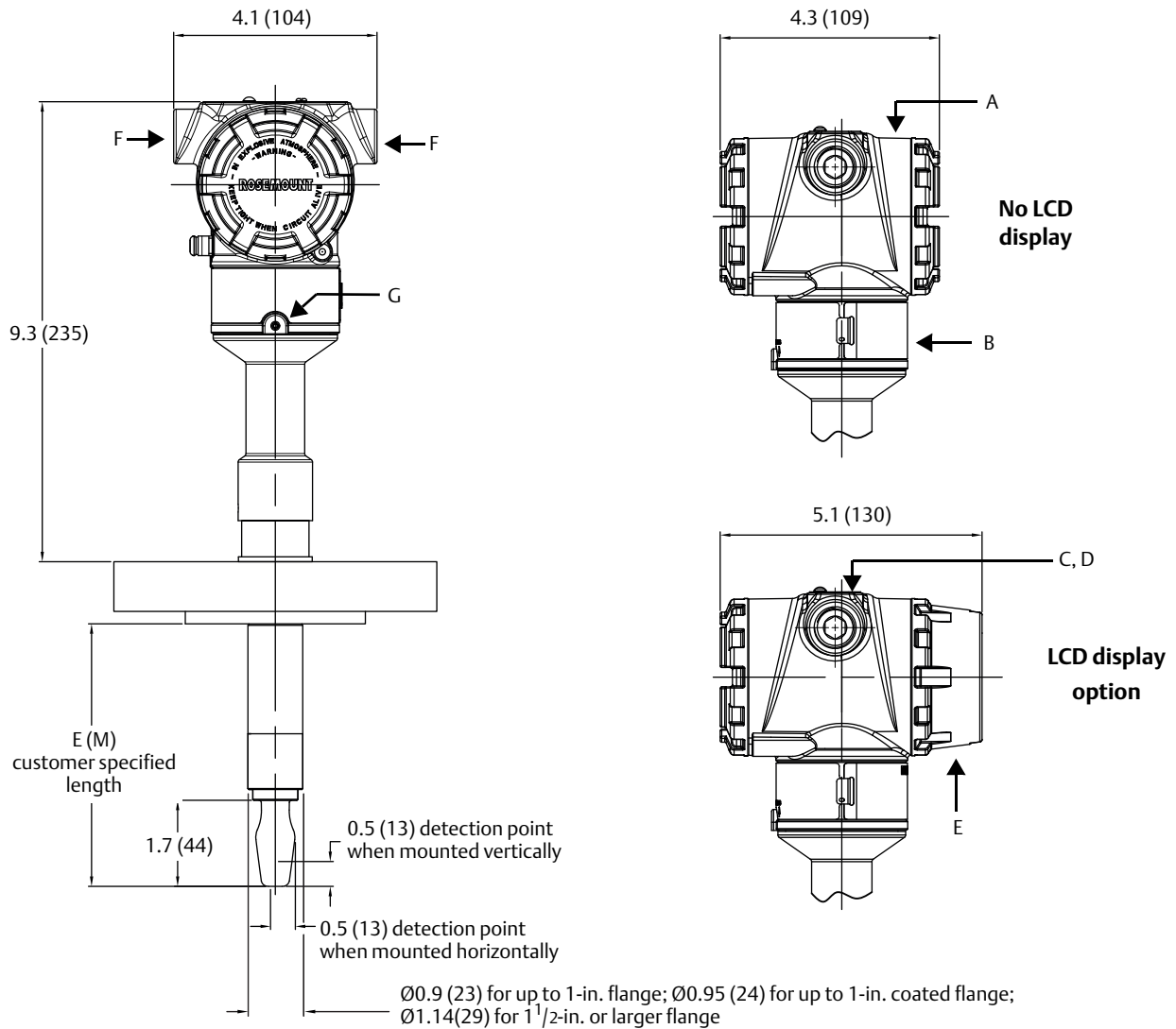

- A. Aluminum or stainless steel housing
 - B. Certification plate
 - C. Cover plate (with logo, product name, and conduit entry size)
 - D. External button(s) under movable plate
 - E. LCD display cover
 - F. Conduit/cable entry M20 x 1.5 or 1/2-in. ANPT
 - G. Housing rotation set screw. Do not unscrew all the way. Rotating the housing, without this screw in place, can damage the internal wiring
- Dimensions are in inches (mm).

Table 10. Fork Length for Flanged Rosemount 2140

Process connection material	Standard length fork length code H	Minimum length fork length code E (M)	Maximum length fork length code E (M)
Stainless steel	4 in. (102 mm)	3.5 in. (89 mm)	157.5 in. (4000 mm)
ECTFE co-polymer coated	4 in. (102 mm)	3.5 in. (89 mm)	59.1 in. (1500 mm)
Alloy C, alloy C-276, solid	4 in. (102 mm)	3.5 in. (89 mm)	157.5 in. (4000 mm)

Figure 13. Flanged Process Connection (High Temperature Range, All Fork Lengths)

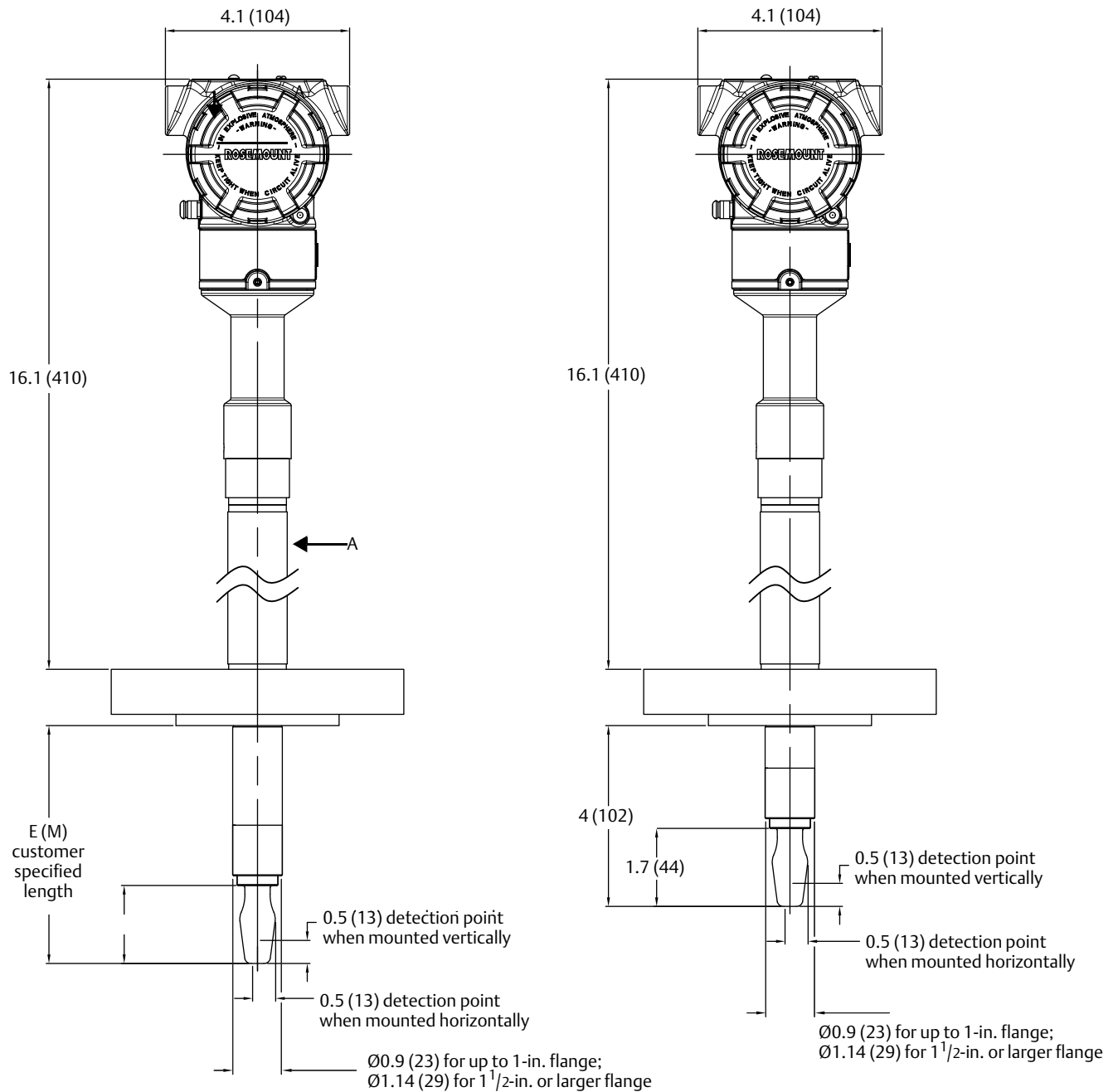

A. Thermal tube.

Dimensions are in inches (mm).

For dimensions and features not shown here, see [Figure 12 on page 24](#).